

YASKAWA AC Drive 1000-Series Option MECHATROLINK-III Installation Manual

Type: SI-ET3

To properly use the product, read this manual thoroughly and retain for easy reference, inspection, and maintenance. Ensure the end user receives this manual.

安川インバータ 1000シリーズオプション MECHATROLINK-III 通信 取扱説明書

形 式 SI-ET3

製品を安全にお使い頂くために、本書を必ずお読みください。
また、本書をお手元に保管していただくとともに、最終的に本製品をご使用になるユーザー様のお手元に確実に届けられるよう、お取り計らい願います。

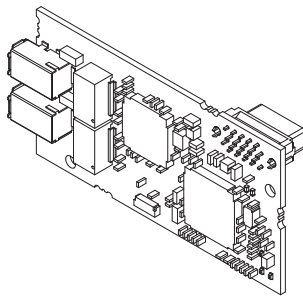

Copyright © 2013 YASKAWA ELECTRIC CORPORATION

All rights reserved. No part of this publication may be reproduced, stored in a retrieval system, or transmitted, in any form or by any means, mechanical, electronic, photocopying, recording, or otherwise, without the prior written permission of Yaskawa. No patent liability is assumed with respect to the use of the information contained herein. Moreover, because Yaskawa is constantly striving to improve its high-quality products, the information contained in this manual is subject to change without notice. Every precaution has been taken in the preparation of this manual. Yaskawa assumes no responsibility for errors or omissions. Neither is any liability assumed for damages resulting from the use of the information contained in this publication.

Table of Contents

1	PREFACE AND SAFETY	4
2	PRODUCT OVERVIEW	9
3	RECEIVING	10
4	OPTION COMPONENTS	11
5	INSTALLATION PROCEDURE	14
6	RELATED DRIVE PARAMETERS	26
7	TROUBLESHOOTING	28
8	SPECIFICATIONS	33

1 Preface and Safety

Yaskawa manufactures products used as components in a wide variety of industrial systems and equipment. The selection and application of Yaskawa products remain the responsibility of the equipment manufacturer or end user. Yaskawa accepts no responsibility for the way its products are incorporated into the final system design. Under no circumstances should any Yaskawa product be incorporated into any product or design as the exclusive or sole safety control. Without exception, all controls should be designed to detect faults dynamically and fail safely under all circumstances. All systems or equipment designed to incorporate a product manufactured by Yaskawa must be supplied to the end user with appropriate warnings and instructions as to the safe use and operation of that part. Any warnings provided by Yaskawa must be promptly provided to the end user. Yaskawa offers an express warranty only as to the quality of its products in conforming to standards and specifications published in the Yaskawa manual. **NO OTHER WARRANTY, EXPRESS OR IMPLIED, IS OFFERED.** Yaskawa assumes no liability for any personal injury, property damage, losses, or claims arising from misapplication of its products.

◆ Applicable Documentation

The following manuals are available for the SI-ET3 option:

SI-ET3 Option

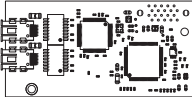
	<p>YASKAWA AC Drive 1000-Series Option SI-ET3 MECHATROLINK-III Installation Manual Manual No: TOBP C730600 62 (This book)</p>	<p>Read this manual first. The installation manual is packaged with the option and contains information required to install the option and set up related drive parameters.</p>
	<p>YASKAWA AC Drive 1000-Series Option SI-ET3 MECHATROLINK-III Technical Manual Manual No: SIEP C730600 62</p>	<p>The technical manual contains detailed information about the option. Access the following sites to obtain the technical manual: U.S.: http://www.yaskawa.com Europe: http://www.yaskawa.eu.com Japan: http://www.e-mechatronics.com For questions, contact your local Yaskawa sales office or the nearest Yaskawa representative.</p>

1 Preface and Safety

Drive

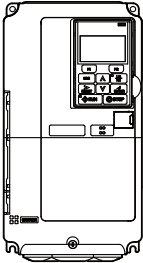
	YASKAWA AC Drive 1000-Series Quick Start Guide	The drive manuals cover basic installation, wiring, operation procedures, functions, troubleshooting, and maintenance information. The manuals also include important information about parameter settings and drive tuning. Access these sites to obtain Yaskawa instruction manuals: U.S.: http://www.yaskawa.com Europe: http://www.yaskawa.eu.com Japan: http://www.e-mechatronics.com For questions, contact your local Yaskawa sales office or the nearest Yaskawa representative.
	YASKAWA AC Drive 1000-Series Technical Manual	

◆ Terms

Note:	Indicates supplemental information that is not related to safety messages.
Drive:	YASKAWA AC Drive 1000-Series
Option:	YASKAWA AC Drive 1000-Series Option SI-ET3 MECHATROLINK-III

◆ Registered Trademarks

- MECHATROLINK-III is a trademark of the MECHATROLINK Members Association (MMA).
- All trademarks are the property of their respective owners.

◆ Supplemental Safety Information

Read and understand this manual before installing, operating, or servicing this option. The option must be installed according to this manual and local codes.

The following conventions are used to indicate safety messages in this manual. Failure to heed these messages could result in serious or possibly even fatal injury or damage to the products or to related equipment and systems.

DANGER

Indicates a hazardous situation, which, if not avoided, will result in death or serious injury.

WARNING

Indicates a hazardous situation, which, if not avoided, could result in death or serious injury.

CAUTION

Indicates a hazardous situation, which, if not avoided, could result in minor or moderate injury.

NOTICE

Indicates an equipment damage message.

1 Preface and Safety

■ General Safety

General Precautions

- The diagrams in this section may include options and drives without covers or safety shields to illustrate details. Be sure to reinstall covers or shields before operating any devices. The option should be used according to the instructions described in this manual.
- Any illustrations, photographs, or examples used in this manual are provided as examples only and may not apply to all products to which this manual is applicable.
- The products and specifications described in this manual or the content and presentation of the manual may be changed without notice to improve the product and/or the manual.
- When ordering new copies of the manual, contact a Yaskawa representative or the nearest Yaskawa sales office and provide the manual number shown on the front cover.

DANGER

Heed the safety messages in this manual.

Failure to comply will result in death or serious injury.

The operator is responsible for injuries or equipment damage caused from failure to heed the warnings in the manual.

NOTICE

Do not modify the drive or option circuitry.

Failure to comply could result in damage to the drive or option and will void warranty.

Yaskawa is not responsible for any modification of the product made by the user. This product must not be modified.

Do not expose the drive or the option to halogen group disinfectants.

Failure to comply may cause damage to the electrical components in the option.

Do not pack the drive in wooden materials that have been fumigated or sterilized.

Do not sterilize the entire package after the product is packed.

2 Product Overview

◆ About This Product

The option provides a communications connection between the drive and a MECHATROLINK-III network. The option connects the drive to a MECHATROLINK-III network and facilitates the exchange of data.

This manual explains the handling, installation and specifications of this product.

MECHATROLINK-III is a communications link to connect industrial devices (such as smart motor controllers, operator interfaces, and variable frequency drives) as well as control devices (such as programmable controllers and computers) to a network.

MECHATROLINK-III is a simple, networking solution that reduces the cost and time to wire and install factory automation devices, while providing interchangeability of like components from multiple vendors.

By installing the option to a drive, it is possible to do the following from a MECHATROLINK-III master device:

- operate the drive
- monitor the operation status of the drive
- change parameter settings

◆ Applicable Models

The option can be used with the drive models in [Table 1](#).

Table 1 Applicable Models

Drive Series	Drive Model Number	Software Version <1>
A1000	CIMR-A□2A□□□□	≥1020
	CIMR-A□4A0002 to 4A0675	≥1020
	CIMR-A□4A0930 and 4A1200	Under development
	CIMR-A□5A□□□□	≥1020

<1> See “PRG” on the drive nameplate for the software version number.

3 Receiving

Please perform the following tasks upon receipt of the option:

- Inspect the option for damage. Contact the shipper immediately if the option appears damaged upon receipt.
- Verify receipt of the correct model by checking the model number printed on the name plate of the option package.
- Contact your supplier if you have received the wrong model or the option does not function properly.

◆ Option Package Components

Table 2 Option Package Contents

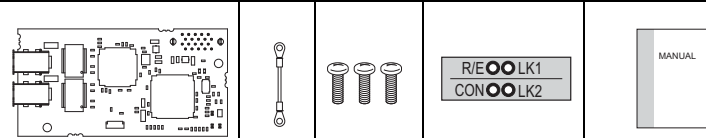
Description:	Option	Ground Wire	Screws (M3)	LED Label	Installation Manual
					
Quantity:	1	1	3	1	1

◆ Tools Required for Installation

- A Phillips screwdriver (M3 metric/#1, #2 U.S. standard size <1>) is required to install the option and remove drive front covers.
- Diagonal cutting pliers. (required for some drive models)
- A small file or medium grit sandpaper. (required for certain drive models)

<1> Screw sizes vary by drive capacity. Select a screwdriver appropriate for the drive capacity.

Note: Tools required to prepare option networking cables for wiring are not listed in this manual.

4 Option Components

◆ SI-ET3 Option

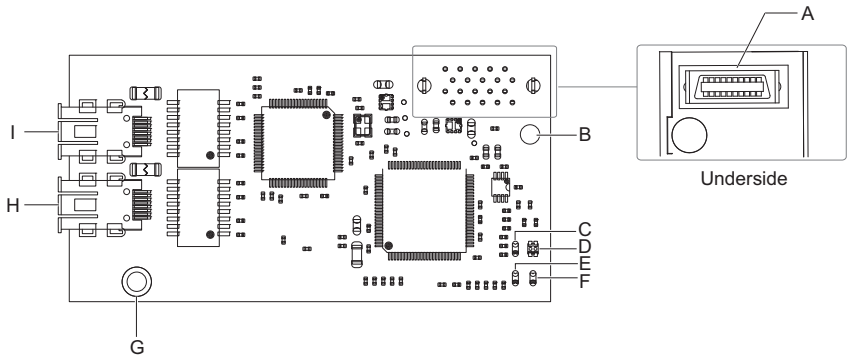

A – Connector (CN5)

B – Installation hole

C – LED (CON) <1>

D – LED (R/E) <1>

E – LED (LK2) <1>

F – LED (LK1) <1>

G – Ground terminal and installation hole <2>

H – Communication connector CN1

I – Communication connector CN2

<1> Refer to *Option LED Display on page 13* for details on the LEDs

<2> The ground wire provided in the option shipping package must be connected during installation

Figure 1 SI-EN3 Option Components

4 Option Components

◆ Connector

Table 3 Communication Connector

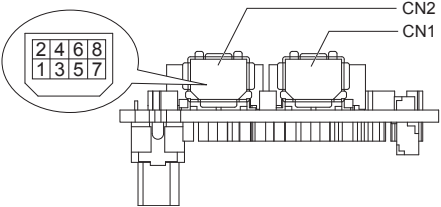
MECHATROLINK-III Connector	Pin No.	Signal Name	I/O	Function
	1	TXD_P	I/O	Send data (+): OUT
	2	TXD_N	I/O	Send data (-): OUT
	3	RXD_P	I/O	Receive data (-): IN
	4	(NC)	–	–
	5	(NC)	–	–
	6	RXD_N	I/O	Receive data (-): IN
	7	(NC)	–	–
	8	(NC)	–	–
	Shell	SLD	–	Shield

◆ Option LED Display

The MECHATROLINK-III Option has four LEDs that indicate the option card or communication status.

■ Checking LED Operation

Table 4 Option LED States

Name	Display	Operating Status	Remarks
R/E	Lit in green	Power supply on	<ul style="list-style-type: none"> • SI-ET3 has been successfully powered up • An internal, self-diagnostic check completed in the SI-ET3
	Lit in red	Error	<ul style="list-style-type: none"> • Error/alarm occurred • Command error occurred (parameter error, phase error, combination error)
	Flashing in red	SI-ET3 error	Error found during SI-ET3's self-diagnostic check
	Unlit	Power supply off	<ul style="list-style-type: none"> • The drive has no power • SI-ET3 is not properly connected to the drive, or SI-ET3 has no power • An internal, self-diagnostic error occurred in the SI-ET3
CON	Lit in green	Connection established	Established connection
	Unlit	Connection unestablished	Connection with master device is not established
LK1	Lit in green	Connector CN1 connected	Connector CN1 is connected to other stations
	Unlit	Connector CN1 disconnected	Connector CN1 is not connected to other stations (cable not connected, cable disconnected, other stations not powered up)
LK2	Lit in green	Connector CN2 connected	Connector CN2 is connected to other stations
	Unlit	Connector CN2 disconnected	Connector CN2 is not connected to other stations (cable not connected, cable disconnected, other stations not powered up)

5 Installation Procedure

◆ Section Safety

DANGER

Electrical Shock Hazard

Do not connect or disconnect wiring while the power is on.

Failure to comply will result in death or serious injury.

Disconnect all power to the drive and wait at least the amount of time specified on the drive front cover safety label.

After all indicators are off, measure the DC bus voltage to confirm safe level, and check for unsafe voltages before servicing. The internal capacitor remains charged after the power supply is turned off.

WARNING

Electrical Shock Hazard

Do not remove the front covers of the drive while the power is on.

Failure to comply could result in death or serious injury.

The diagrams in this section may include options and drives without covers or safety shields to show details. Be sure to reinstall covers or shields before operating any devices. The option should be used according to the instructions described in this manual.

Do not allow unqualified personnel to use equipment.

Failure to comply could result in death or serious injury.

Maintenance, inspection, and replacement of parts must be performed only by authorized personnel familiar with installation, adjustment, and maintenance of this product.

Do not touch circuit boards while the power to the drive is on.

Failure to comply could result in death or serious injury.



WARNING

Do not use damaged wires, place excessive stress on wiring, or damage the wire insulation.

Failure to comply could result in death or serious injury.

Fire Hazard

Tighten all terminal screws to the specified tightening torque.

Loose electrical connections could result in death or serious injury by fire due to overheating of electrical connections.

NOTICE

Damage to Equipment

Observe proper electrostatic discharge (ESD) procedures when handling the option, drive, and circuit boards.

Failure to comply may result in ESD damage to circuitry.

Never shut the power off while the drive is outputting voltage.

Failure to comply may cause the application to operate incorrectly or damage the drive.

Do not operate damaged equipment.

Failure to comply may cause further damage to the equipment.

Do not connect or operate any equipment with visible damage or missing parts.

Do not use unshielded cable for control wiring.

Failure to comply may cause electrical interference resulting in poor system performance.

Use shielded twisted-pair wires and ground the shield to the ground terminal of the drive.

5 Installation Procedure

NOTICE

Properly connect all pins and connectors.

Failure to comply may prevent proper operation and possibly damage equipment.

Check wiring to ensure that all connections are correct after installing the option and connecting any other devices.

Failure to comply may result in damage to the option.

◆ Prior to Installing the Option

Prior to installing the option, wire the drive, make necessary connections to the drive terminals, and verify that the drive functions normally without the option installed. Refer to the instruction manual packaged with the drive for information on wiring and connecting the drive.

Figure 2 shows an exploded view of the drive with the option and related components for reference.

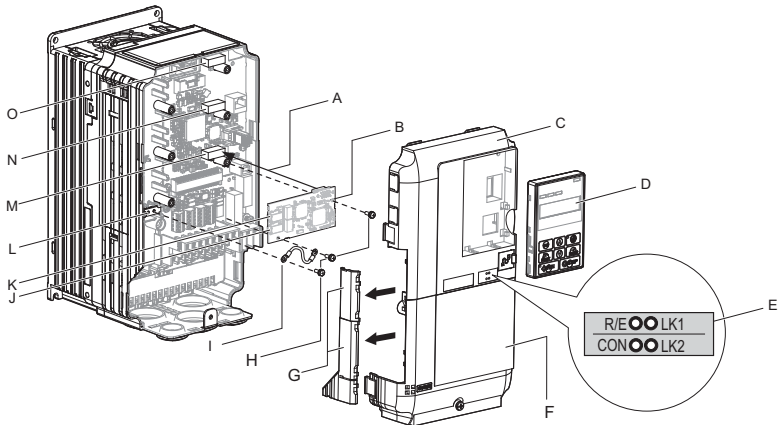

A – Insertion point for CN5 connector
B – SI-ET3 option
C – Drive front cover
D – Digital operator
E – LED label
F – Drive terminal cover
G – Removable tabs for wire routing
H – Included screws

I – Ground wire
J – Option modular connector CN1
K – Option modular connector CN2
L – Drive grounding terminal (FE)
M – Connector CN5-A
N – Connector CN5-B
O – Connector CN5-C

Figure 2 Drive Components with Option

5 Installation Procedure

◆ Installing the Option

Remove the front covers of the drive before installing the option. Refer to the drive instruction manual for directions on removing the front covers. Cover removal varies depending on drive size. This option can be inserted only into the **CN5-A** connector located on the drive control board.

DANGER! Electrical Shock Hazard. Do not connect or disconnect wiring while the power is on. Failure to comply could result in death or serious injury. Before installing the option, disconnect all power to the drive and wait at least the amount of time specified on the drive front cover safety label. After all indicators are off, measure the DC bus voltage to confirm safe level, and check for unsafe voltages before servicing. The internal capacitor remains charged after the power supply is turned off.

1. Shut off power to the drive, wait the appropriate amount of time for voltage to dissipate, then remove the digital operator (D) and front covers (C, F). Cover removal varies depending on drive size.

NOTICE: Damage to Equipment. Observe proper electrostatic discharge procedures (ESD) when handling the option, drive, and circuit boards. Failure to comply may result in ESD damage to circuitry.

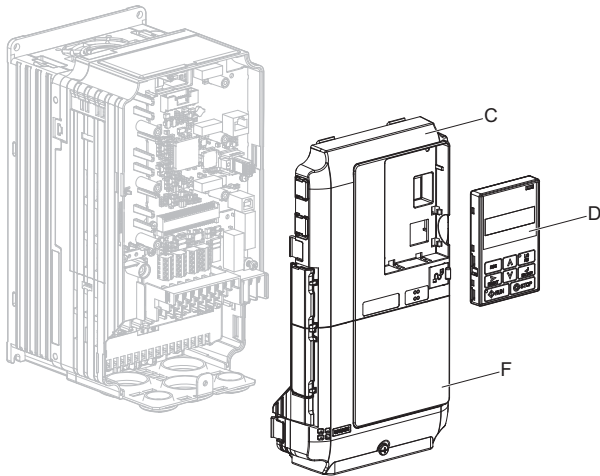

Figure 3 Remove the Front Covers and Digital Operator

2. With the front covers and digital operator removed, apply the LED label (E) in the appropriate position on the drive top front cover (C).

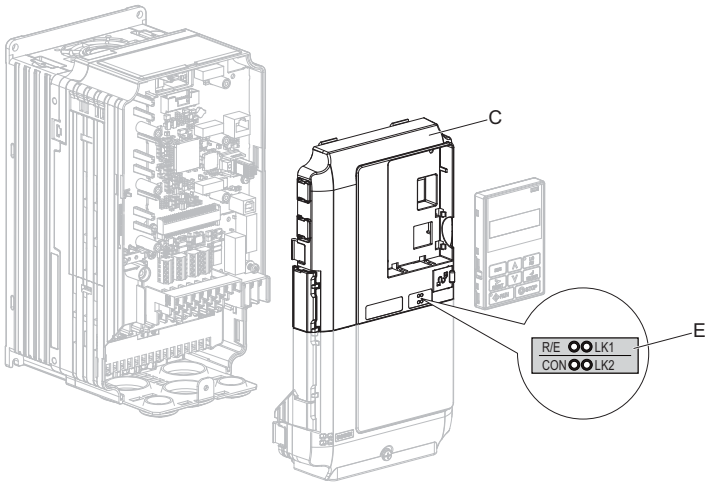

Figure 4 Apply the LED Label

3. Insert the option (B) into the CN5-A connector (M) located on the drive and fasten it using one of the included screws (H).

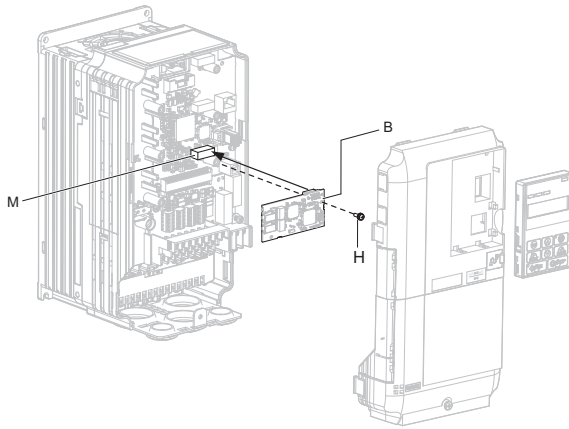

Figure 5 Insert the Option

5 Installation Procedure

4. Connect the ground wire (I) to the ground terminal (L) using one of the remaining provided screws (H). Connect the other end of the ground wire (I) to the remaining ground terminal and installation hole on the option (B) using the last remaining provided screw (H) and tighten both screws to 0.5 to 0.6 N·m (4.4 to 5.3 in lbs).

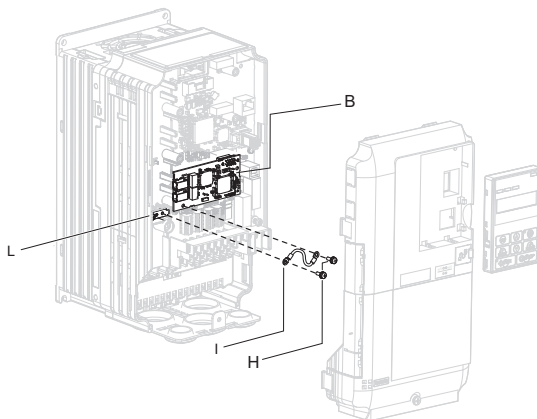

Figure 6 Connect the Ground Wire

Note: There are two screw holes on the drive for use as ground terminals (L). When connecting three options, two ground wires will need to share the same drive ground terminal.

5. Route the option wiring.

Depending on the drive model, some drives may require routing the wiring through the side of the front cover to the outside to provide adequate space for the wiring. Refer to the Peripheral Devices & Options section of the drive Quick Start Guide or instruction manual for more information on wire routing of specific models. Route the wiring through the side of the front cover to the outside. In these cases, using diagonal cutting pliers, cut out the perforated openings on the left side of the drive front cover as shown in [Figure 7-A](#). Sharp edges along the cut out should be smoothed down with a file or sand paper to prevent any damage to the wires. Route the wiring inside the enclosure as shown in [Figure 7-B](#) for drives that do not require routing through the front cover.

Note: Separate communication cables from main circuit wiring and other electrical lines.

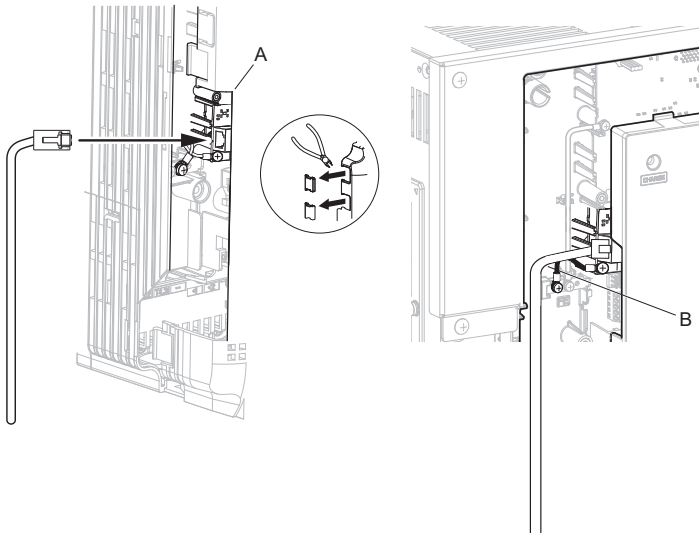

A – Route wires through the openings provided on the left side of the front cover. <1>

B – Use the open space provided inside the drive to route option wiring.

<1> The drive will not meet NEMA Type 1 requirements if wiring is exposed outside the enclosure.

Figure 7 Wire Routing Examples

5 Installation Procedure

6. Connect the MECHATROLINK-III communication cable to option communication connector CN1 or CN2. Refer to [Communication Cable Wiring on page 23](#) for details.
Install MECHATROLINK-III communications cables apart from main-circuit wiring and other electrical and power lines. Ensure the cable end is firmly connected (see [Figure 7](#)).

Note: Maximum transmission distance is 100 m (3937.0 in.). Minimum wiring distance between stations is 0.2 m (7.9 in.).

Connection Diagram

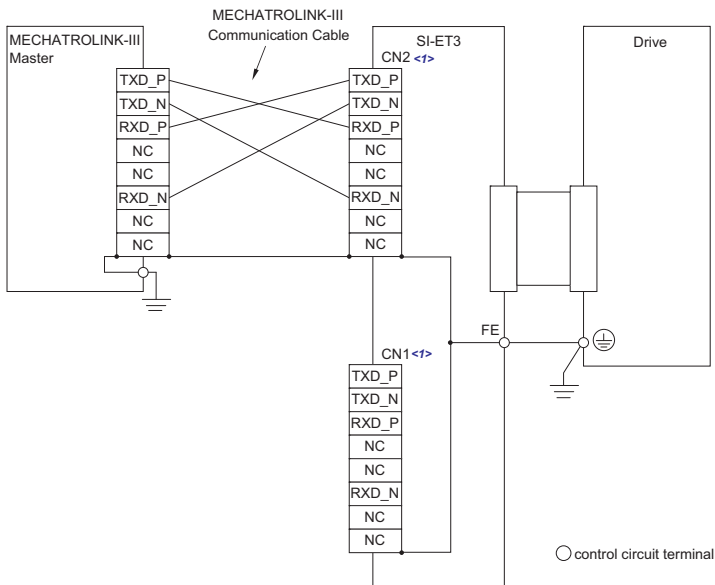

<f> Use connector CN1 or CN2 to connect with the MECHATROLINK-III master. Refer to [Communication Cable Wiring on page 23](#) for details.

Figure 8 Option Connection Diagram

Communication Cable Wiring

The dual communication cable ports on the option board act as a switch to allow for flexibility in cabling topology. For example, a traditional star network topology may be employed by using a single port on the option board. Alternatively, a daisychained approach may be employed by using both communication cable ports. This second approach reduces the requirements of MECHATROLINK-III hub module ports.

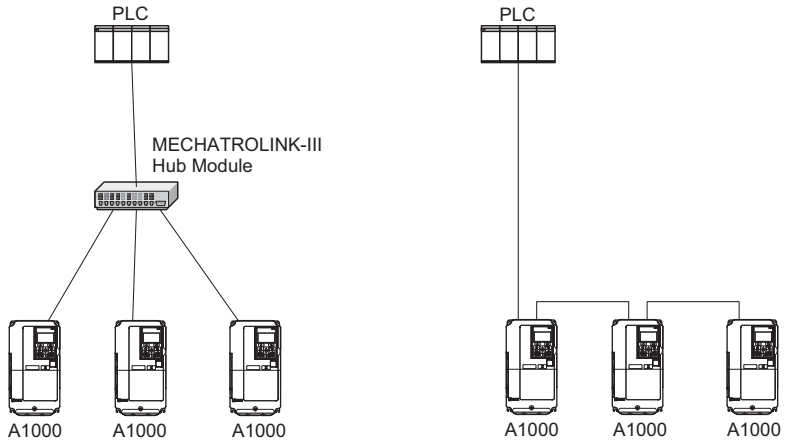
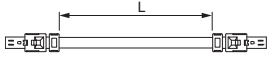
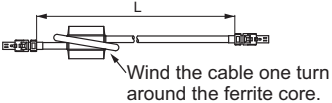
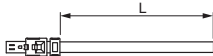

Figure 9 Topology Options

5 Installation Procedure

Table 5 MECHATROLINK-III Communication Cable

Connection Type	Cable Specification	Length (L)	Model
MECHATROLINK-III connection without ferrite core		0.2 m (7.9 in.)	JEPMC-W6012-A2-E
		0.5 m (19.7 in.)	JEPMC-W6012-A5-E
		1 m (39.4 in.)	JEPMC-W6012-01-E
		2 m (78.7 in.)	JEPMC-W6012-02-E
		3 m (118.1 in.)	JEPMC-W6012-03-E
		4 m (157.5 in.)	JEPMC-W6012-04-E
		5 m (196.9 in.)	JEPMC-W6012-05-E
		10 m (393.7 in.)	JEPMC-W6012-10-E
		20 m (787.4 in.)	JEPMC-W6012-20-E
		30 m (1181.1 in.)	JEPMC-W6012-30-E
50 m (1968.5 in.)	JEPMC-W6012-50-E		
MECHATROLINK-III connection with ferrite core		10 m (393.7 in.)	JEPMC-W6013-10-E
		20 m (787.4 in.)	JEPMC-W6013-20-E
		30 m (1181.1 in.)	JEPMC-W6013-30-E
		50 m (1968.5 in.)	JEPMC-W6013-50-E
		75 m (2952.8 in.)	JEPMC-W6013-75-E
100 m (3937.0 in.)	JEPMC-W6013-100-E		
MECHATROLINK-III connection with loose wires at one end		0.5 m (19.7 in.)	JEPMC-W6014-A5-E
		1 m (39.4 in.)	JEPMC-W6014-01-E
		3 m (118.1 in.)	JEPMC-W6014-03-E
		5 m (196.9 in.)	JEPMC-W6014-05-E
		10 m (393.7 in.)	JEPMC-W6014-10-E
		30 m (1181.1 in.)	JEPMC-W6014-30-E
50 m (1968.5 in.)	JEPMC-W6014-50-E		

7. Replace and secure the front covers of the drive (C, F) and replace the digital operator (D).

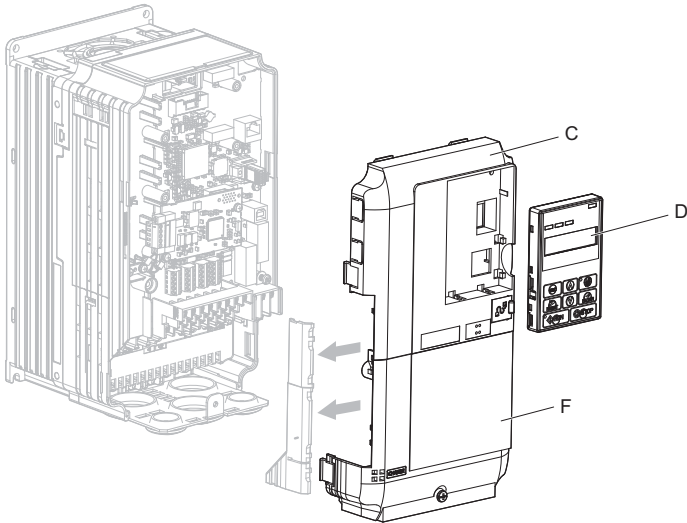

Figure 10 Replace the Front Covers and Digital Operator

Note: Take proper precautions when wiring the option so that the front covers will easily fit back onto the drive. Make sure no cables are pinched between the front covers and the drive when replacing the covers.

8. Set drive parameters in [Table 6](#) for proper option performance.

6 Related Drive Parameters

The following parameters are used to set up the drive for operation with the option. Parameter setting instructions can be found in the drive Quick Start Guide or instruction manual.

Confirm proper setting of the all parameters in **Table 6** using the digital operator before starting network communications.

Table 6 Related Parameter Settings

No. (Addr. Hex)	Name	Description	Values
b1-01 (180) </>	Frequency Reference Selection	Selects the frequency reference input source. 0: Operator - Digital preset speed d1-01 to d1-17 1: Terminals - Analog input terminal A1 or A2 2: MEMOBUS/Modbus communications 3: Option 4: Pulse Input (Terminal RP)	Default: 1 Range: 0 to 4 (Set to 3)
b1-02 (181) </>	Run Command Selection	Selects the run command input source. 0: Digital Operator - RUN and STOP keys 1: Digital input terminals S1 to S8 2: MEMOBUS/Modbus communications 3: Option	Default: 1 Range: 0 to 3 (Set to 3)
F6-01 (3A2)	Operation Selection after Communications Error	Determines drive response when a bUS error is detected during communications with the option. 0: Ramp to Stop 1: Coast to Stop 2: Fast-Stop 3: Alarm Only </>	Default: 1 Range: 0 to 3
F6-02 (3A3)	External Fault Detection Conditions (EF0)	Sets the condition for external fault detection (EF0). 0: Always detected 1: Detected only during operation	Default: 0 Range: 0, 1
F6-03 (3A4)	Stopping Method for External Fault from the Communication Option	Determines drive response for external fault input (EF0) detection during option communications. 0: Ramp to Stop 1: Coast to Stop 2: Fast-Stop 3: Alarm Only </>	Default: 1 Range: 0 to 3
F6-06 (3A7) </>	Torque Reference/Torque Limit Selection from the Communication Option	0: Torque Reference/Torque Limit via network communications are disabled. 1: Torque Reference/Torque Limit via network communications are enabled. </>	Default: 0 Range: 0, 1
F6-07 (3A8)	NetRef/ComRef Selection Function	0: Multi-step speed reference disabled (F7 functionality) 1: Multi-step speed reference allowed (V7 functionality)	Default: 0 Range: 0, 1

6 Related Drive Parameters

No. (Addr. Hex)	Name	Description	Values
F6-08 (36A)	Reset Communication Related Parameters	Determines if communication-related parameters F6-□□ and F7-□□ are set back to original default values when the drive is initialized using parameter A1-03. 0: Do not reset parameters 1: Reset parameters	Default: 0 Range: 0, 1
F6-20 <5> <6>	MECHATROLINK Station Address	Sets the station number.	Default: 21H Range: 20 to 3FH
F6-21 <5>	MECHATROLINK Frame Size	Sets the frame size. 0: 64 byte 1: 32 byte	Default: 0 Range: 0, 1
F6-23 <5> <7>	MECHATROLINK Monitor Selection (Code 0EH)	Set MEMOBUS/Modbus register to monitor SEL_MON of INV_CTL and INV_CTL.	Default: 0H Range: 0 to FFFFH
F6-24 <5> <8>	MECHATROLINK Monitor Selection (Code 0FH)	Set MEMOBUS/Modbus register to monitor SEL_MON of INV_CTL and INV_CTL.	Default: 0H Range: 0 to FFFFH
F6-25	Operation Selection at Watchdog Error (E5)	0: Ramp to stop. Decelerate to stop using the deceleration time in C1-02. 1: Coast to stop. 2: Fast Stop. Decelerate to stop using the deceleration time in C1-09. 3: Alarm only.	Default: 1 Range: 0 to 3
F6-26	MECHATROLINK bUS Errors Detected	Sets the number of option communication errors (bUS).	Default: 2 Range: 2 to 10

- <1> To start and stop the drive with the MECHATROLINK-III master device using serial communications, set b1-02 to 3. To control the frequency reference of the drive via the master device, set b1-01 to 3.
- <2> If set to 3, then the drive will continue to operate when a fault is detected. Take proper measures such as installing an emergency stop switch.
- <3> Enabled in CLV, AOLV/PM, and CLV/PM control modes (A1-02 = 3, 6, or 7). When enabled, d5-01 determines whether the value is read as the Torque Limit value (d5-01 = 0) or read as the Torque Reference value (d5-01 = 1). In CLV/PM, this value is read as the Torque Limit.
- <4> The setting specifies that the Torque Reference or Torque Limit is to be provided via network communications (F6-06 = 1). The motor may rotate if no torque reference or Torque Limit is supplied from the PLC.
- <5> Power must be cycled in order for any setting changes to take affect.
- <6> All station addresses must be unique. If set to 20 or 3F, a Station Address Error (AEr) will occur and the ERR light will turn on.
- <7> Setting byte 10 of INV_CTL to 0EH enables the register set by F6-23. Byte 11 and 12 of the response data enable the register content set by F6-23. Refer to the drive instruction manual for details on the register that can be set.
- <8> Setting byte 10 of INV_CTL to 0FH enables the register set by F6-24. Byte 11 and 12 of the response data enable the register content set by F6-24. Refer to the drive instruction manual for details on the register that can be set.

7 Troubleshooting

◆ Drive-Side Error Codes

Drive-side error codes appear on the drive digital operator. Causes of the errors and corrective actions are listed in [Table 7](#). For additional error codes that may appear on the drive digital operator, refer to the drive Technical Manual.

■ Faults

Both bUS (option communication error) and EF0 (External fault input from the option) can appear as an alarm or as a fault. When a fault occurs, the digital operator ALM LED remains lit. When an alarm occurs, the ALM LED flashes.

If communication stops while the drive is running, use the following questions as a guide to help remedy the fault:

- Is the option properly installed?
- Is the communication line properly connected to the option? Is it loose?
- Is the controller program working? Has the controller/PLC CPU stopped?
- Did a momentary power loss interrupt communications?

Table 7 Fault Display and Possible Solutions

LED Operator Display		Fault Name
<i>bUS</i>	bUS	Option Communication Error
		<ul style="list-style-type: none"> • After establishing initial communication, the connection was lost • Only detected when the run command or frequency reference is assigned to the option (b1-01 = 3 or b1-02 = 3)
Cause		Possible Solution
Master controller (PLC) has stopped communicating		<ul style="list-style-type: none"> • Check that power is supplied to the PLC • Check that PLC is not in program mode
Communication cable is not connected properly		<ul style="list-style-type: none"> • Check for faulty wiring • Correct any wiring problems
A data error occurred due to electric interference		<ul style="list-style-type: none"> • Inspect items that can minimize the effects of electrical noise • Counteract noise in the control circuit, main circuit, and ground wiring • If a magnetic contactor is identified as a source of noise, install a surge absorber to the contactor coil • Make sure the cable used meets the MECHATROLINK-III requirements • Make sure the option ground wire is connected between option FE terminal and the drive ground terminal connected to earth ground
Option is damaged		If there are no problems with the wiring and the error continues to occur, replace the option.
Connection Time-out		<ul style="list-style-type: none"> • The option Requested Packet Interval (RPI) timer timed out • Make sure that RPI time is set properly

Duplicate Station Address	Check if the option shares Station Address with at least one other node. Check the setting values of F6-20.
---------------------------	--

LED Operator Display		Fault Name
<i>E5</i>	E5	MECHATROLINK Watchdog Timer Error The watchdog has timed out.
Cause		Possible Solution
Data has not been received from the PLC, triggering the watchdog timer.		⇒ Execute DISCONNECT or ALM_CLR, then issue a CONNECT command or SYNC_SET command and proceed to phase 3.

LED Operator Display		Fault Name
<i>EF0</i>	EF0	Option Card External Fault The alarm function for an external device has been triggered.
Cause		Corrective Action
An external fault is being sent from the upper controller (PLC)		<ul style="list-style-type: none"> • Remove the cause of the external fault • Reset the external fault input from the PLC device
Problem with the PLC program		Check the program used by the PLC and make the appropriate corrections.
PLC is in the Idle Mode.		<ul style="list-style-type: none"> • Set the PLC to the Run Mode • Set the drive parameter F6-54 to 0 (Enabled) not to detect errors while the PLC is in the Idle Mode

LED Operator Display		Fault Name
<i>oFA00</i>	oFA00	Option Card Connection Error (CN5-A) Option is not properly connected.
Cause		Possible Solution
Non-compatible option connected to the drive		Connect an option that is compatible with the drive.

LED Operator Display		Fault Name
<i>oFA01</i>	oFA01	Option Card Fault (CN5-A) Option is not properly connected.
Cause		Possible Solution
Problem with the connectors between the drive and option		Turn the power off and check the connectors between the drive and option.

7 Troubleshooting

LED Operator Display		Fault Name
oFA30 to oFA43	oFA30 to oFA43	Option Card Connection Error (CN5-A)
		Communication ID error.
Cause		Possible Solution
Option hardware fault		Replace the option.

LED Operator Display		Fault Name
oFb00	oFb00	Option Fault (CN5-B)
		Non-compatible option is connected.
Cause		Possible Solution
Non-compatible option connected to the drive.		Connect the correct option to CN5-A.

LED Operator Display		Fault Name
oFb02	oFb02	Option Fault (CN5-B)
		Two identical options are connected at the same time.
Cause		Possible Solution
Options AI-A3 or DI-A3 are connected to the CN5-B port with an option connected to CN5-A.		<ul style="list-style-type: none"> Only one type of AI-A3, DI-A3 or SI-□□ option can be connected to the drive The SI-ET3 option can only be connected to CN5-A

LED Operator Display		Fault Name
oFC00	oFC00	Option Fault (CN5-C)
		Non-compatible option is connected.
Cause		Possible Solution
Non-compatible option connected to the drive.		Connect the correct option to CN5-A.

LED Operator Display		Fault Name
oFC02	oFC02	Option Fault
		Option Flash write mode.
Cause		Possible Solution
Options AI-A3 or DI-A3 are connected to the CN5-B port while an option connected to CN5-A.		<ul style="list-style-type: none"> Only one type of AI-A3, DI-A3 or SI-□□ option can be connected to the drive The SI-ET3 option can only be connected to CN5-A

■ Minor Faults and Alarms

LED Operator Display		Minor Fault Name	
[ALL]	CALL	Serial communication transmission error Communication is not established.	
Cause		Possible Solution	Minor Fault (H2-□□ = 10)
Communication wiring is faulty, there is a short circuit, or improper connection.		Check for wiring errors: <ul style="list-style-type: none"> • Correct the wiring • Remove ground shorts and reconnect loose wires 	YES
Programming error on the master side.		Check communications at start-up and correct programming errors.	
Communication circuitry is damaged.		<ul style="list-style-type: none"> • Perform a self-diagnostics check • Replace the drive if the fault continues to occur 	

LED Operator Display		Minor Fault Name	
[YC]	CYC	Transmission Cycle Setting Error Transmission cycle from the master controller (PLC) was out of range.	
Cause		Possible Solution	Minor Fault (H2-□□ = 10)
Transmission cycle of the option set in the master controller (PLC) was out of range.		Set the transmission cycle of the master controller in the range of 250 μs, 500 μs, 750 μs, and 1 to 32 ms (0.5 ms increment). Make sure to set the communication cycle to 32 ms or less.	YES

7 Troubleshooting

◆ Prior to Installing the Option

Prior to installing the option, wire the drive, make the necessary connections to the drive terminals, and verify that the drive functions normally. Refer to the [Table 8](#) for information on wiring and connecting the drive.

[Table 8](#) below lists the number of option cards that can be connected to the drive and the drive connectors for connecting those option cards.

Table 8 Option Card Installation

Option Card	Connector	Number of Cards Possible
PG-B3, PG-X3	CN5-C	2 <1>
PG-RT3 <2> <3>, PG-F3 <2> <3>	CN5-C	1
DO-A3, AO-A3	CN5-A, B, C	1
SI-C3, SI-N3, SI-P3, SI-S3, SI-T3, SI-ET3, AI-A3, DI-A3, SI-ES3, SI-B3, SI-M3, SI-W3, SI-EM3, SI-EN3, SI-EP3 <4>	CN5-A	1

- <1> If two PG option cards are connected, use both CN5-B and CN5-C. If only one PG option card is connected to the drive, use the CN5-C connector.
- <2> These option cards are not available for the application with Motor 2 Selection.
- <3> These option cards are not available with models CIMR-A□4A0930 and 4A1200.
- <4> When AI-A3 and DI-A3 are to be used as monitors, the card can be connected to any of CN5-A, CN5-B or CN5-C. The input status of AI-A3 can then be viewed using U1-21, U1-22, and U1-23, and the input status of DI-A3 can then be viewed using U1-17.

8 Specifications

◆ Specifications

Table 9 Option Specifications

Item	Specification
Model	SI-ET3
Access mode	Start-stop synchronization, master/slave method
Communication speed	100 Mbps
Minimum transmission cycle	250 μ s
Maximum transmission cycle	8 ms
Transmission cycle granularity	03H
Minimum wiring distance between stations	0.2 m (7.9 in.)
Maximum wiring distance between stations	100 m (3937.0 in.)
Data length	32-byte data transmission or 64-byte data transmission
Event driven communication	Valid
Profile	Compliant with standard inverter profile
Maximum number of stations	62 </>
Ambient temperature	-10°C to +50°C (14°F to 122°F)
Humidity	95% RH or lower with no condensation
Storage temperature	-20°C to +60°C (-4°F to 140°F) allowed for short-term transport of the product
Area of use	Indoor (free of corrosive gas, airborne particles, etc.)
Altitude	1000 m (3280 ft.) or lower

<1> The maximum number of connectable stations changes depending on the types and settings of the host controller, baud rate, or communications cycle. For details, refer to the controller manual.

8 Specifications

◆ Revision History

Revision dates and manual numbers appear on the bottom of the back cover.

MANUAL NO. TOBP C730600 62B

Published in Japan August 2013 13-4 ◊

└─ Revision number
└─ Date of original publication
└─ Date of publication

Date of Publication	Revision Number	Section	Revised Content
August 2013	◊	All	Revision: Manual number
April 2013	—	—	First edition

YASKAWA AC Drive 1000-Series Option MECHATROLINK-III Installation Manual

DRIVE CENTER (INVERTER PLANT)

2-13-1, Nishimiyaichi, Yukuhashi, Fukuoka, 824-8511, Japan
Phone: 81-930-25-3844 Fax: 81-930-25-4369
<http://www.yaskawa.co.jp>

YASKAWA ELECTRIC CORPORATION

New Pier Takeshiba South Tower, 1-16-1, Kaigan, Minatoku, Tokyo, 105-6891, Japan
Phone: 81-3-5402-4502 Fax: 81-3-5402-4580
<http://www.yaskawa.co.jp>

YASKAWA AMERICA, INC.

2121 Norman Drive South, Waukegan, IL 60085, U.S.A.
Phone: 1-800-YASKAWA (927-5292) or 1-847-887-7300 Fax: 1-847-887-7310
<http://www.yaskawa.com>

YASKAWA ELÉTRICO DO BRASIL LTDA.

Avenida Piraporinha 777, Diadema, São Paulo, 09950-000, Brasil
Phone: 55-11-3585-1100 Fax: 55-11-3585-1187
<http://www.yaskawa.com.br>

YASKAWA EUROPE GmbH

Hauptstrasse 185, 65760 Eschborn, Germany
Phone: 49-6196-569-300 Fax: 49-6196-569-398
<http://www.yaskawa.eu.com>

YASKAWA ELECTRIC KOREA CORPORATION

9F Kyobo Securities Bldg., 26-4, Yeouido-dong, Yeongdeungpo-gu, Seoul, 150-737, Korea
Phone: 82-2-784-7844 Fax: 82-2-784-8495
<http://www.yaskawa.co.kr>

YASKAWA ELECTRIC (SINGAPORE) PTE. LTD.

151 Lorong Chuan, #04-02A, New Tech Park, 556741, Singapore
Phone: 65-6282-3003 Fax: 65-6289-3003
<http://www.yaskawa.com.sg>

YASKAWA ELECTRIC (CHINA) CO., LTD.

12F, Carlton Bldg., No.21 HuangHe Road, HuangPu District, Shanghai 200003, China
Phone: 86-21-5385-2200 Fax: 86-21-5385-3299
<http://www.yaskawa.com.cn>

YASKAWA ELECTRIC (CHINA) CO., LTD. BEIJING OFFICE

Room 1011, Tower W3 Oriental Plaza, No. 1 East Chang An Ave.,
Dong Cheng District, Beijing, 100738, China
Phone: 86-10-8518-4086 Fax: 86-10-8518-4082

YASKAWA ELECTRIC TAIWAN CORPORATION

9F, 16, Nanking E. Rd., Sec. 3, Taipei, 104, Taiwan
Phone: 886-2-2502-5009 Fax: 886-2-2505-1280

YASKAWA INDIA PRIVATE LIMITED

#17A Electronics City, Hosur Road Bangalore 560 100 (Karnataka), India
Phone: 91-80-4244-1900 Fax: 91-80-4244-1901
<http://www.yaskawaindia.in>



YASKAWA ELECTRIC CORPORATION

In the event that the end user of this product is to be the military and said product is to be employed in any weapons systems or the manufacture thereof, the export will fall under the relevant regulations as stipulated in the Foreign Exchange and Foreign Trade Regulations. Therefore, be sure to follow all procedures and submit all relevant documentation according to any and all rules, regulations and laws that may apply. Specifications are subject to change without notice for ongoing product modifications and improvements.

© 2013 YASKAWA ELECTRIC CORPORATION. All rights reserved.

MANUAL NO. TOBP C730600 62B

Published in Japan August 2013 13-4 ◇-0
13-7-11