

YASKAWA AC Drive 1000-Series Option

EtherNet/IP

Installation Manual

Type: SI-EN3

To properly use the product, read this manual thoroughly and retain for easy reference, inspection, and maintenance. Ensure the end user receives this manual.

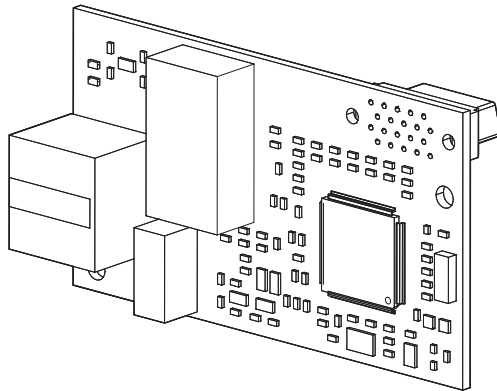

Copyright © 2012 YASKAWA ELECTRIC CORPORATION

All rights reserved. No part of this publication may be reproduced, stored in a retrieval system, or transmitted, in any form or by any means, mechanical, electronic, photocopying, recording, or otherwise, without the prior written permission of Yaskawa. No patent liability is assumed with respect to the use of the information contained herein. Moreover, because Yaskawa is constantly striving to improve its high-quality products, the information contained in this manual is subject to change without notice. Every precaution has been taken in the preparation of this manual. Yaskawa assumes no responsibility for errors or omissions. Neither is any liability assumed for damages resulting from the use of the information contained in this publication.

Table of Contents

1 PREFACE AND SAFETY	2
2 PRODUCT OVERVIEW	6
3 RECEIVING	7
4 OPTION COMPONENTS	8
5 INSTALLATION PROCEDURE	11
6 RELATED DRIVE PARAMETERS	21
7 CONFIGURING MESSAGING	25
8 OUTPUT ASSEMBLIES (DRIVE CONSUMES)	26
9 INPUT ASSEMBLIES (DRIVE PRODUCES)	28
10 WEB INTERFACE	30
11 TROUBLESHOOTING	34
12 SPECIFICATIONS	40

1 Preface and Safety

Yaskawa manufactures products used as components in a wide variety of industrial systems and equipment. The selection and application of Yaskawa products remain the responsibility of the equipment manufacturer or end user. Yaskawa accepts no responsibility for the way its products are incorporated into the final system design. Under no circumstances should any Yaskawa product be incorporated into any product or design as the exclusive or sole safety control. Without exception, all controls should be designed to detect faults dynamically and fail safely under all circumstances. All systems or equipment designed to incorporate a product manufactured by Yaskawa must be supplied to the end user with appropriate warnings and instructions as to the safe use and operation of that part. Any warnings provided by Yaskawa must be promptly provided to the end user. Yaskawa offers an express warranty only as to the quality of its products in conforming to standards and specifications published in the Yaskawa manual. **NO OTHER WARRANTY, EXPRESS OR IMPLIED, IS OFFERED.** Yaskawa assumes no liability for any personal injury, property damage, losses, or claims arising from misapplication of its products.

◆ Applicable Documentation

The following manuals are available for the SI-EN3 option:

SI-EN3 Option

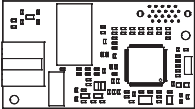
	Yaskawa AC Drive 1000-Series Option SI-EN3 EtherNet/IP Installation Manual Manual No: TOBP C730600 58 (This book)	Read this manual first. The installation manual is packaged with the option and contains information required to install the option and set up related drive parameters.
	Yaskawa AC Drive 1000-Series Option SI-EN3 EtherNet/IP Technical Manual Manual No: SIEP C730600 58	The technical manual contains detailed information about the option. Access the following sites to obtain the technical manual: U.S.: http://www.yaskawa.com Europe: http://www.yaskawa.eu.com Japan: http://www.e-mechatronics.com For questions, contact your local Yaskawa sales office or the nearest Yaskawa representative.

Yaskawa Drive

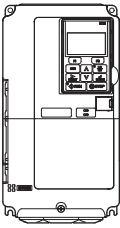
	Yaskawa AC Drive 1000-Series Quick Start Guide	The drive manuals cover basic installation, wiring, operation procedures, functions, troubleshooting, and maintenance information. The manuals also include important information about parameter settings and drive tuning.
	Yaskawa AC Drive 1000-Series Technical Manual	Access these sites to obtain Yaskawa instruction manuals: U.S.: http://www.yaskawa.com Europe: http://www.yaskawa.eu.com Japan: http://www.e-mechatronics.com For questions, contact your local Yaskawa sales office or the nearest Yaskawa representative.

◆ Terms

Note:	Indicates supplemental information that is not related to safety messages.
Drive:	Yaskawa AC Drive 1000-Series
Option:	Yaskawa AC Drive 1000-Series Option SI-EN3 EtherNet/IP

◆ Registered Trademarks

- EtherNet/IP is a trademark of the ODVA.
- All trademarks are the property of their respective owners.

◆ Supplemental Safety Information

Read and understand this manual before installing, operating, or servicing this option. The option must be installed according to this manual and local codes.

The following conventions are used to indicate safety messages in this manual. Failure to heed these messages could result in serious or possibly even fatal injury or damage to the products or to related equipment and systems.

 **DANGER**

Indicates a hazardous situation, which, if not avoided, will result in death or serious injury.

1 Preface and Safety

WARNING

Indicates a hazardous situation, which, if not avoided, could result in death or serious injury.

CAUTION

Indicates a hazardous situation, which, if not avoided, could result in minor or moderate injury.

NOTICE

Indicates an equipment damage message.

■ General Safety

General Precautions

- The diagrams in this section may include options and drives without covers or safety shields to illustrate details. Be sure to reinstall covers or shields before operating any devices. The option should be used according to the instructions described in this manual.
- Any illustrations, photographs, or examples used in this manual are provided as examples only and may not apply to all products to which this manual is applicable.
- The products and specifications described in this manual or the content and presentation of the manual may be changed without notice to improve the product and/or the manual.
- When ordering new copies of the manual, contact a Yaskawa representative or the nearest Yaskawa sales office and provide the manual number shown on the front cover.

DANGER

Heed the safety messages in this manual.

Failure to comply will result in death or serious injury.

The operator is responsible for injuries or equipment damage caused from failure to heed the warnings in the manual.

NOTICE

Do not expose the drive or the option to halogen group disinfectants.

Failure to comply may cause damage to the electrical components in the option.

Do not pack the drive in wooden materials that have been fumigated or sterilized.

Do not sterilize the entire package after the product is packed.

Do not modify the drive or option circuitry.

Failure to comply could result in damage to the drive or option and will void warranty.

Yaskawa is not responsible for any modification of the product made by the user. This product must not be modified.

2 Product Overview

◆ About This Product

The option provides a communications connection between the drive and an ODVA EtherNet/IP network. The option connects the drive to an EtherNet/IP network and facilitates the exchange of data.

This manual explains the handling, installation and specifications of this product.

EtherNet/IP is a communications link to connect industrial devices (such as smart motor controllers, operator interfaces, and variable frequency drives) as well as control devices (such as programmable controllers and computers) to a network. EtherNet/IP is a simple, networking solution that reduces the cost and time to wire and install factory automation devices, while providing interchangeability of like components from multiple vendors.

EtherNet/IP is an open device network standard.

By installing the option to a drive, it is possible to do the following from an EtherNet/IP master device:

- operate the drive
- monitor the operation status of the drive
- change parameter settings.



◆ Applicable Models

The option can be used with the drive models in [Table 1](#).

Table 1 Applicable Models

Drive Series	Drive Model Number	Software Version <1>
A1000	CIMR-A□2A□□□□	≥ 1010
	CIMR-A□4A0002 to 4A0675	≥ 1010
	CIMR-A□4A0930 and 4A1200	301□
	CIMR-A□5A□□□□	504□

<1> See “PRG” on the drive nameplate for the software version number.





3 Receiving

Please perform the following tasks upon receipt of the option:

- Inspect the option for damage. Contact the shipper immediately if the option appears damaged upon receipt.
- Verify receipt of the correct model by checking the model number printed on the name plate of the option package.
- Contact your supplier if you have received the wrong model or the option does not function properly.

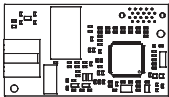
◆ Option Package Components

Table 2 Option Package Contents

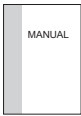
Description:	Option	Ground Wire	Screws (M3)	LED Label	Installation Manual
—					
Quantity:	1	1	3	1	1

◆ Tools Required for Installation

- A Phillips screwdriver (M3 metric/#1, #2 U.S. standard size <1>) is required to install the option and remove drive front covers.
- Diagonal cutting pliers. (required for some drive models)
- A small file or medium grit sandpaper. (required for certain drive models)

<1> Screw sizes vary by drive capacity. Select a screwdriver appropriate for the drive capacity.

Note: Tools required to prepare option networking cables for wiring are not listed in this manual.

4 Option Components

◆ SI-EN3 Option

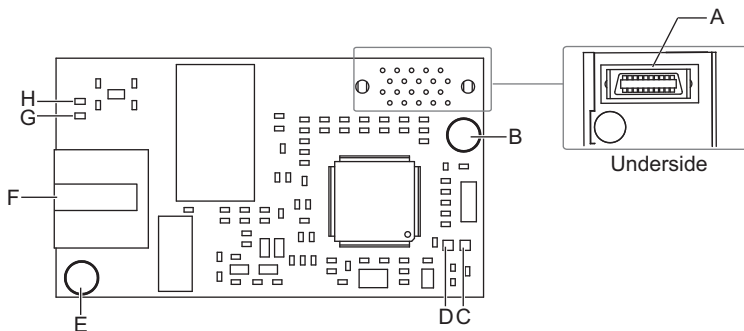

A – Connector (CN5)

B – Installation hole

C – LED (MS) <2>

D – LED (NS) <2>

E – Ground terminal and installation hole <1>

F – Communication connector CN1 (RJ45)

G – LED (LINK/ACT) <2>

H – LED (10/100) <2>

<1> The ground wire provided in the option shipping package must be connected during installation

<2> Refer to *Option LED Display* on page 9 for details on the LEDs

Figure 1 SI-EN3 Option Components

◆ Communication Connector CN1

The communication connector on the option is a modular RJ45 female connector designated CN1.

CN1 is the connection point for a customer supplied male Ethernet network communication cable.

Table 3 Male 8-way Ethernet Modular Connector (Customer Supplied)

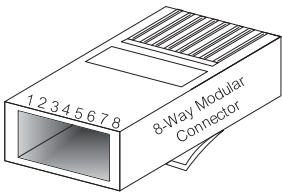
Male EtherNet 8-Way Modular Connector	Pin	Description
	1 (Pair 2)	Transmit data (TXD) +
	2 (Pair 2)	Transmit data (TXD) -
	3 (Pair 3)	Receive data (RXD) +
	4 (Pair 1)	Not used </>
	5 (Pair 1)	Not used </>
	6 (Pair 3)	Receive data (RXD) -
	7 (Pair 4)	Not used </>
	8 (Pair 4)	Not used </>

</> Not used for 10 Mbps and 100 Mbps networks.

◆ Option LED Display

The option has four LEDs:

Bi-color Status LEDs:

- Module status (MS) red/green
- Network status (NS) red/green

Green Ethernet LEDs:

- Network speed-10/100 (MS) green
- Link status and network activity-Link/Act (NS) red/green

The operational states of the option LEDs after the power-up diagnostic LED sequence is completed are described in [Table 4](#). Wait at least 2 seconds for the power-up diagnostic process to complete before verifying the states of the LEDs.

Table 4 Option LED States

Name	Indication		Operating Status	Remarks
	Color	Status		
MS	–	OFF	Power supply OFF	Power is not being supplied to the drive
	Green	ON	Option operating	The option is operating normally
	Green	Flashing	Option initializing	The option is configuring an IP address
	Red	ON	Fatal error occurred	The option has detected a fatal (unrecoverable) error
	Red	Flashing	Non-fatal error occurred	The option has detected a non-fatal (recoverable) error
	Green/Red	Flashing	Option self-test	The option is in self-test mode

4 Option Components

Name	Indication		Operating Status	Remarks
	Color	Status		
NS	–	OFF	Offline or Power supply OFF	–
	Green	ON	Online communications established	The option is online and has established connections
	Green	Flashing	Online communications not established	The option is online without an established connection
	Red	ON	Communications error (fatal)	The option detected a duplicate IP address
	Red	Flashing	Communications time-out (non-fatal)	A communications time-out occurred
	Green/Red	Flashing	Option self-test	The option is in self-test mode
10/100 </>	Green	OFF	10 Mbps is established	–
	Green	ON	100 Mbps is established	
LINK/ACT </>	Green	OFF	Link is not established	
	Green	ON	Link is established	
	Green	Flashing	Link is established and there is network activity	

<1> Remove the drive front cover to check the status of the LED. Be careful not to touch the main circuit terminals or the control board in the drive.

■ Power-Up Diagnostics

An LED test is performed each time the drive is powered up. The initial boot sequence may take several seconds. After the LEDs have completed the diagnostic LED sequence, the option is successfully initialized. The LEDs then assume operational conditions as shown in [Table 4](#).

Table 5 Power-Up Diagnostic LED Sequence

Sequence	Module Status (MS)	Network Status (NS)	Time (ms)
1	Green	OFF	250
2	Red	OFF	250
3	Green	OFF	–
4	Green	Green	250
5	Green	Red	250
6	Green	OFF	–

5 Installation Procedure

◆ Section Safety

DANGER

Electrical Shock Hazard

Do not connect or disconnect wiring while the power is on.

Failure to comply will result in death or serious injury.

Disconnect all power to the drive and wait at least the amount of time specified on the drive front cover safety label.

After all indicators are off, measure the DC bus voltage to confirm safe level, and check for unsafe voltages before servicing. The internal capacitor remains charged after the power supply is turned off.

WARNING

Electrical Shock Hazard

Do not remove the front covers of the drive while the power is on.

Failure to comply could result in death or serious injury.

The diagrams in this section may include options and drives without covers or safety shields to show details. Be sure to reinstall covers or shields before operating any devices. The option should be used according to the instructions described in this manual.

Do not allow unqualified personnel to use equipment.

Failure to comply could result in death or serious injury.

Maintenance, inspection, and replacement of parts must be performed only by authorized personnel familiar with installation, adjustment, and maintenance of this product.

Do not touch circuit boards while the power to the drive is on.

Failure to comply could result in death or serious injury.

5 Installation Procedure

WARNING

Do not use damaged wires, place excessive stress on wiring, or damage the wire insulation.

Failure to comply could result in death or serious injury.

Fire Hazard

Tighten all terminal screws to the specified tightening torque.

Loose electrical connections could result in death or serious injury by fire due to overheating of electrical connections.

NOTICE

Damage to Equipment

Observe proper electrostatic discharge (ESD) procedures when handling the option, drive, and circuit boards.

Failure to comply may result in ESD damage to circuitry.

Never shut the power off while the drive is outputting voltage.

Failure to comply may cause the application to operate incorrectly or damage the drive.

Do not operate damaged equipment.

Failure to comply may cause further damage to the equipment.

Do not connect or operate any equipment with visible damage or missing parts.

Do not use unshielded cable for control wiring.

Failure to comply may cause electrical interference resulting in poor system performance.

Use shielded twisted-pair wires and ground the shield to the ground terminal of the drive.

NOTICE

Properly connect all pins and connectors.

Failure to comply may prevent proper operation and possibly damage equipment.

Check wiring to ensure that all connections are correct after installing the option and connecting any other devices.

Failure to comply may result in damage to the option.

5 Installation Procedure

◆ Prior to Installing the Option

Prior to installing the option, wire the drive, make necessary connections to the drive terminals, and verify that the drive functions normally without the option installed. Refer to the Quick Start Guide packaged with the drive for information on wiring and connecting the drive.

Figure 2 shows an exploded view of the drive with the option and related components for reference.

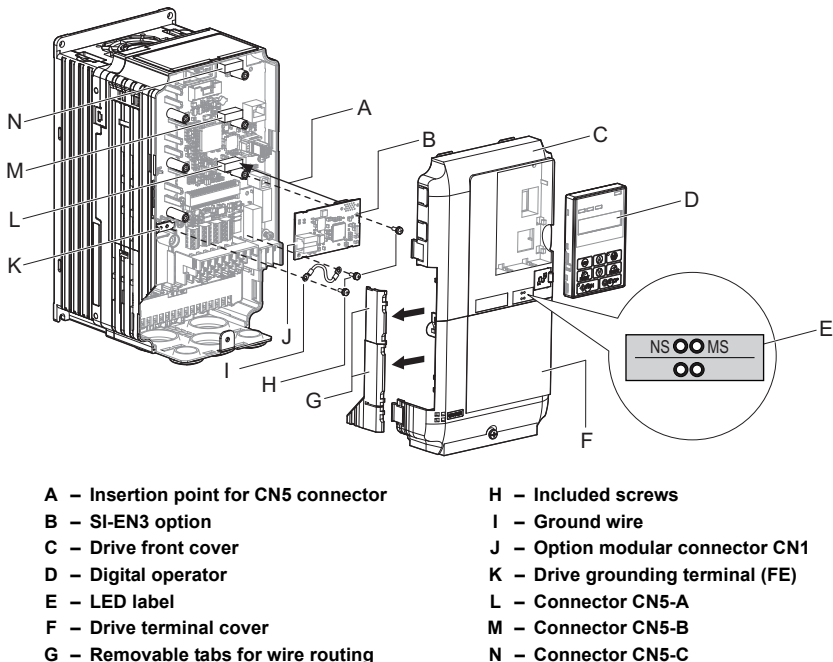

Figure 2 Drive Components with Option

◆ Installing the Option

Remove the front covers of the drive before installing the option. Refer to the drive Quick Start Guide for directions on removing the front covers. Cover removal varies depending on

5 Installation Procedure

drive size. This option can be inserted only into the **CN5-A** connector located on the drive control board.

DANGER! *Electrical Shock Hazard. Disconnect all power to the drive and wait at least the amount of time specified on the drive front cover safety label. After all indicators are off, measure the DC bus voltage to confirm safe level, and check for unsafe voltages before servicing to prevent electric shock. The internal capacitor remains charged even after the power supply is turned off.*

1. Shut off power to the drive, wait the appropriate amount of time for voltage to dissipate, then remove the digital operator (D) and front covers (C, F). Front cover removal varies by model.

NOTICE: *Damage to Equipment. Observe proper electrostatic discharge procedures (ESD) when handling the option, drive, and circuit boards. Failure to comply may result in ESD damage to circuitry.*

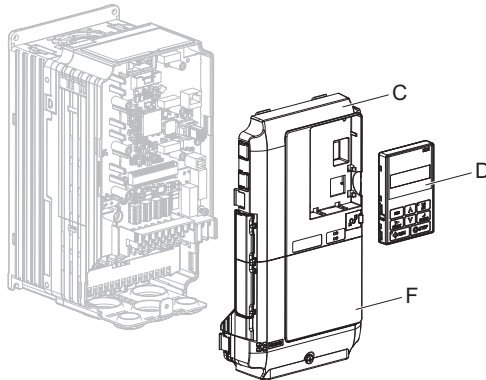

Figure 3 Remove the Front Covers and Digital Operator

5 Installation Procedure

2. With the front covers and digital operator removed, apply the LED label (E) in the appropriate position on the drive top front cover (C).

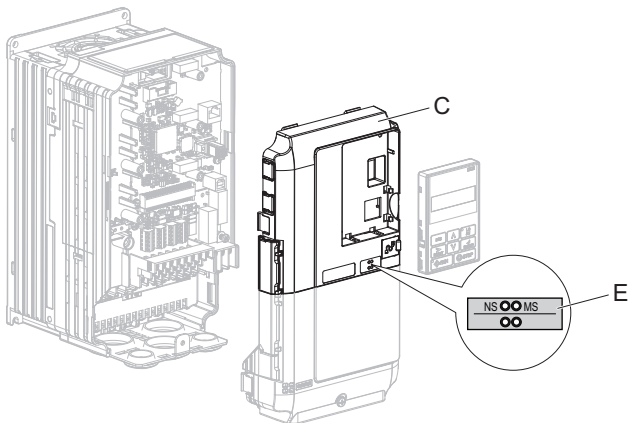

Figure 4 Apply the LED Label

3. Insert the option (B) into the **CN5-A** connector (L) located on the drive and fasten it using one of the included screws (H).

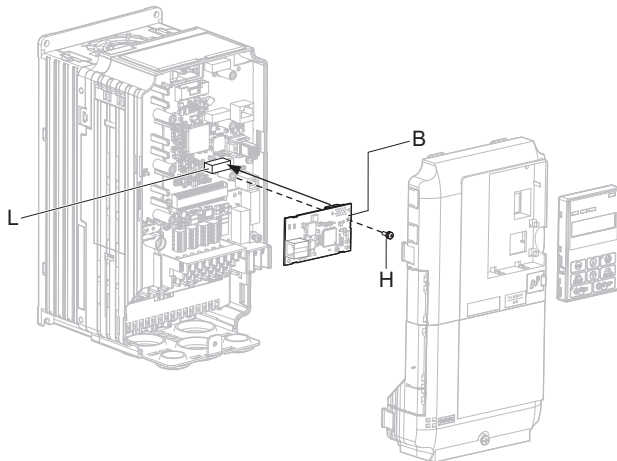

Figure 5 Insert the Option

4. Connect the ground wire (I) to the ground terminal (K) using one of the remaining provided screws (H). Connect the other end of the ground wire (I) to the remaining ground terminal and installation hole on the option (B) using the last remaining provided screw (H) and tighten both screws to 0.5 to 0.6 N·m or (4.4 to 5.3 in lbs).

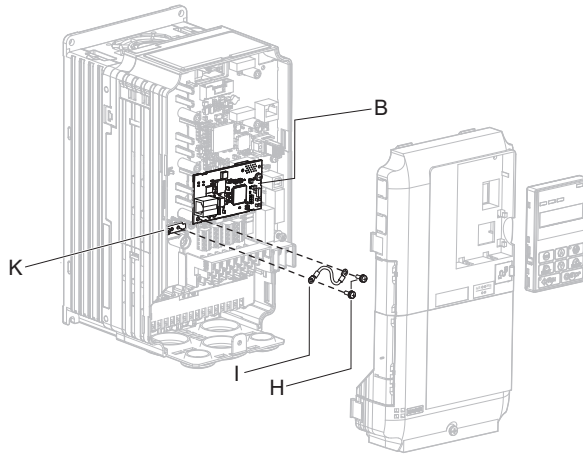

Figure 6 Connect the Ground Wire

Note: There are two screw holes on the drive for use as ground terminals. When connecting three options, two ground wires will need to share the same drive ground terminal.

5 Installation Procedure

5. Route the option wiring.

Depending on the drive model, some drives may require routing the wiring through the side of the front cover to the outside to provide adequate space for the wiring. Refer to the Peripheral Devices & Options section of the drive Quick Start Guide or Technical Manual for more information on wire routing of specific models.

Route the wiring through the side of the front cover to the outside. In these cases, using diagonal cutting pliers, cut out the perforated openings on the left side of the drive front cover as shown in *Figure 7-A*. Sharp edges along the cut out should be smoothed down with a file or sand paper to prevent any damage to the wires. Route the wiring inside the enclosure as shown in *Figure 7-B* for drives that do not require routing through the front cover.

Note: Separate communication cables from main circuit wiring and other electrical lines.

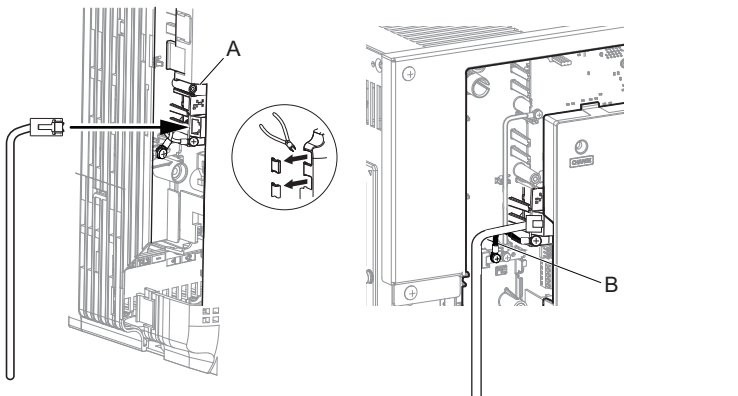

A – Route wires through the openings provided on the left side of the front cover. <1>

B – Use the open space provided inside the drive to route option wiring.

<1> The drive will not meet NEMA Type 1 requirements if wiring is exposed outside the enclosure.

Figure 7 Wire Routing Examples

- Connect the Ethernet communication cable to the option modular connector (CN1). To connect the option to a network, insert the RJ45 connector of the Cat 5e patch cable into the option modular connector (CN1). Ensure the cable end is firmly connected (see [Figure 7](#)).

IGMP Snooping

Switches implementing IGMP Snooping are strongly recommended. When IGMP Snooping is used, devices will only receive the multicast packets in which they are interested.

Communication Cable Specifications

Only use cable recommended for EtherNet/Industrial Protocol (EtherNet/IP™). Using a cable not specifically recommended may cause the option or drive to malfunction. Refer to the ODVA website for more information on network cabling (<http://www.odva.org>).

Connection Diagram

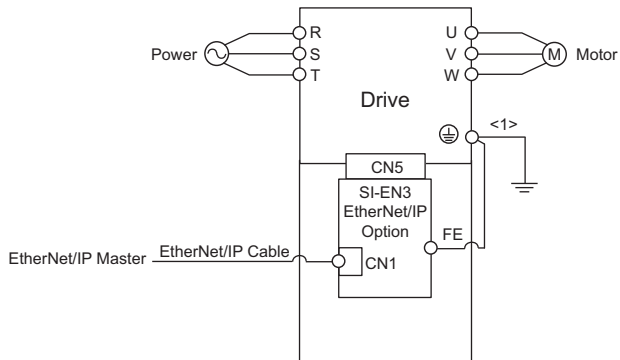

<1> The ground wire provided in the option shipping package must be connected during installation.

Figure 8 Wiring Diagram

5 Installation Procedure

7. Replace and secure the front covers of the drive (C, F) and replace the digital operator (D).

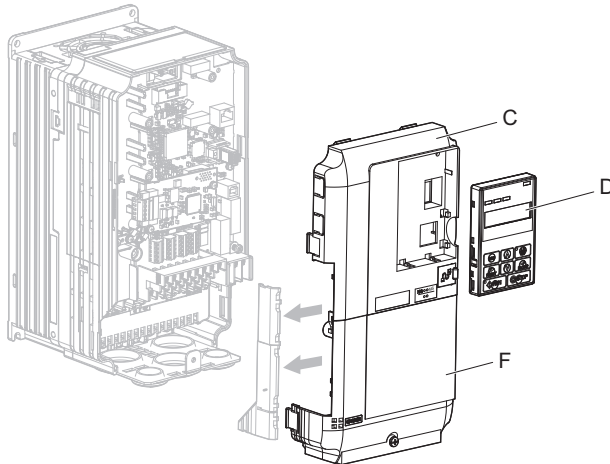

Figure 9 Replace the Front Covers and Digital Operator

Note: Take proper precautions when wiring the option so that the front covers will easily fit back onto the drive. Make sure no cables are pinched between the front covers and the drive when replacing the covers.

8. Set drive parameters in [Table 6](#) for proper option performance.

◆ EDS Files

For easy network implementation of drives equipped with the option, an EDS file can be obtained from:

U.S.: <http://www.yaskawa.com>

Europe: <http://www.yaskawa.eu.com>

Japan: <http://www.e-mechatronics.com>

Other areas: Contact a Yaskawa representative.

Note: Download the EDS file for SI-EN3 option. The SI-EN3 will not function as a slave in the network without the appropriate EDS file.

6 Related Drive Parameters

The following parameters are used to set up the drive for operation with the option. Parameter setting instructions can be found in the drive Quick Start Guide or Technical Manual.

Confirm proper setting of the all parameters in [Table 6](#) using the digital operator, before starting network communications.

Table 6 Related Parameter Settings

No. (Addr. Hex)	Name	Description	Values
b1-01 (180) <I>	Frequency Reference Selection	Selects the frequency reference input source. 0: Operator - Digital preset speed d1-01 to d1-17 1: Terminals - Analog input terminal A1 or A2 2: MEMOBUS/Modbus communications 3: Option 4: Pulse Input (Terminal RP)	Default: 1 Range: 0 to 4 (Set to 3)
b1-02 (181) <I>	Run Command Selection	Selects the run command input source. 0: Digital Operator - RUN and STOP keys 1: Digital input terminals S1 to S8 2: MEMOBUS/Modbus communications 3: Option	Default: 1 Range: 0 to 3 (Set to 3)
F6-01 (3A2)	Operation Selection after Communications Error	Determines drive response when a BUS error is detected during communications with the option. 0: Ramp to Stop 1: Coast to Stop 2: Fast-Stop 3: Alarm Only <2>	Default: 1 Range: 0 to 3
F6-02 (3A3)	External Fault Detection Conditions (EF0)	Sets the condition for external fault detection (EF0). 0: Always detected 1: Detected only during operation	Default: 0 Range: 0, 1
F6-03 (3A4)	Stopping Method for External Fault from the Communication Option	Determines drive response for external fault input (EF0) detection during option communications. 0: Ramp to Stop 1: Coast to Stop 2: Fast-Stop 3: Alarm Only <2>	Default: 1 Range: 0 to 3
F6-06 (3A7) <3>	Torque Reference/Torque Limit Selection from the Communication Option	0: Torque Reference/Torque Limit via network communications are disabled. 1: Torque Reference/Torque Limit via network communications are enabled. <4>	Default: 0 Range: 0, 1

6 Related Drive Parameters

No. (Addr. Hex)	Name	Description	Values
F6-07 (3A8)	NetRef/ComRef Selection Function	0: Multi-step speed reference disabled, (F7 functionality) 1: Multi-step speed reference allowed (V7 functionality)	Default: 0 Range: 0, 1
F6-08 (36A)	Reset Communication Related Parameters	Determines if communication-related parameters F6-□□ and F7-□□ are set back to original default values when the drive is initialized using parameter A1-03. 0: Do not reset parameters 1: Reset parameters	Default: 0 <?> Range: 0, 1
F7-01 (3E5) <?> <?> <?>	IP Address 1	Sets the static/fixed IP address. Parameter F7-01 sets the most significant octet.	Default: 192 Range: 0 to 255
F7-02 (3E6) <?> <?> <?>	IP Address 2	Sets the static/fixed IP address. Parameter F7-02 sets the second most significant octet.	Default: 168 Range: 0 to 255
F7-03 (3E7) <?> <?> <?>	IP Address 3	Sets the static/fixed IP address. Parameter F7-03 sets the third most significant octet.	Default: 1 Range: 0 to 255
F7-04 (3E8) <?> <?> <?>	IP Address 4	Sets the static/fixed IP address. Parameter F7-04 sets the fourth most significant octet.	Default: 20 Range: 0 to 255
F7-05 (3E9) <?>	Subnet Mask 1	Sets the static/fixed Subnet Mask. Parameter F7-05 sets the most significant octet.	Default: 255 Range: 0 to 255
F7-06 (3EA) <?>	Subnet Mask 2	Sets the static/fixed Subnet Mask. Parameter F7-06 sets the second most significant octet.	Default: 255 Range: 0 to 255
F7-07 (3EB) <?>	Subnet Mask 3	Sets the static/fixed Subnet Mask. Parameter F7-07 sets the third most significant octet.	Default: 255 Range: 0 to 255
F7-08 (3EC) <?>	Subnet Mask 4	Sets the static/fixed Subnet Mask. Parameter F7-08 sets the fourth most significant octet.	Default: 0 Range: 0 to 255
F7-09 (3ED) <?>	Gateway Address 1	Sets the static/fixed Gateway address. Parameter F7-09 sets the most significant octet.	Default: 192 Range: 0 to 255
F7-10 (3EE) <?>	Gateway Address 2	Sets the static/fixed Gateway address. Parameter F7-10 sets the second most significant octet.	Default: 168 Range: 0 to 255
F7-11 (3EF) <?>	Gateway Address 3	Sets the static/fixed Gateway address. Parameter F7-11 sets the third most significant octet.	Default: 1 Range: 0 to 255

6 Related Drive Parameters

No. (Addr. Hex)	Name	Description	Values
F7-12 (3E0) <7>	Gateway Address 4	Sets the static/fixed Gateway address. Parameter F7-12 sets the fourth most significant octet.	Default: 1 Range: 0 to 255
F7-13 (3F1)	Address Mode at Startup	Selects how the option address is set. 0: Static <6> 1: BOOTP 2: DHCP	Default: 2 Range: 0 to 2
F7-14 (3F2)	Duplex Mode Selection	Selects duplex mode setting. 0: Half duplex forced 1: Auto-negotiate 2: Full duplex forced	Default: 1 Range: 0 to 2
F7-15 (3F3) <8>	Communication Speed Selection	Sets the communication speed 10: 10 Mbps 100: 100 Mbps	Default: 10 Range: 10, 100
F7-17 (3F5)	EtherNet/IP Speed Scaling Factor	Sets the scaling factor for the speed monitor in EtherNet/IP Class ID 2AH Object.	Default: 0 Min.: -15 Max.: 15
F7-18 (3F6)	EtherNet/IP Current Scaling Factor	Sets the scaling factor for the output current monitor in EtherNet/IP Class ID 2AH Object.	Default: 0 Min.: -15 Max.: 15
F7-19 (3F7)	EtherNet/IP Torque Scaling Factor	Sets the scaling factor for the torque monitor in EtherNet/IP Class ID 2AH Object.	Default: 0 Min.: -15 Max.: 15
F7-20 (3F8)	EtherNet/IP Power Scaling Factor	Sets the scaling factor for the power monitor in EtherNet/IP Class ID 2AH Object.	Default: 0 Min.: -15 Max.: 15
F7-21 (3F9)	EtherNet/IP Voltage Scaling Factor	Sets the scaling factor for the voltage monitor in EtherNet/IP Class ID 2AH Object.	Default: 0 Min.: -15 Max.: 15
F7-22 (3FA)	EtherNet/IP Time Scaling	Sets the scaling factor for the time monitor in EtherNet/IP Class ID 2AH Object.	Default: 0 Min.: -15 Max.: 15
F7-23 to F7-32 (3FB to 404)	Dynamic Output Assembly Parameters	Parameters used in Output Assembly 116. Each parameter contains a MEMOBUS/Modbus address. The value received for Output Assembly 116 will be written to this corresponding MEMOBUS/Modbus address. A MEMOBUS/Modbus address value of 0 means that the value received for Output Assembly 116 will not be written to any MEMOBUS/Modbus register.	Default: 0

6 Related Drive Parameters

No. (Addr. Hex)	Name	Description	Values
F7-33 to F7-42 (405 to 40E)	Dynamic Input Assembly Parameters	Parameters used in Input Assembly 166. Each parameter contains a MEMOBUS/Modbus address. The value sent for Input Assembly 166 will be read from this corresponding MEMOBUS/Modbus address. A MEMOBUS/Modbus address value of 0 means that the value sent for Input Assembly 166 is not defined by the user, therefore the option default register value will be returned. <i>Refer to Input Assemblies (Drive Produces) on page 28</i> for definitions of the default MEMOBUS/Modbus registers.	Default: 0

- <1> To start and stop the drive with the EtherNet/IP master device using serial communications, set b1-02 to 3 or set the "Net Control" bit in the assemblies or Control Supervisor Object. To control the drive frequency reference of the drive via the master device, set b1-01 to 3 or set the Net Reference bit in the assemblies or AC/DC Object.
- <2> If F6-01 is set to 3, the drive will continue to operate when a fault is detected. Take safety measures, such as installing an emergency stop switch.
- <3> Enabled in CLV, AOLV/PM, and CLV/PM control modes (A1-02 = 3, 6, or 7). When enabled, d5-01 determines whether the value is read as the Torque Limit value (d5-01 = 0) or read as the Torque Reference value (d5-01 = 1). In CLV/PM, this value is read as the Torque Limit.
- <4> The setting specifies that the Torque Reference or Torque Limit is to be provided via network communications (F6-06 = 1). The motor may rotate if no torque reference or Torque Limit is supplied from the PLC.
- <5> Cycle power for setting changes to take effect.
- <6> If F7-13 is set to 0, then all IP Addresses (F7-01 to F7-04) must be unique.
- <7> Set F7-01 to F7-12 when F7-13 is set to 0.
- <8> Set F7-15 when F7-14 is set to 0 or 2.

Table 7 Option Monitors

No.	Name	Description	Value Range
U6-80 to U6-83	Online IP Address	IP Address currently available; U6-80 is the most significant octet	0 to 255
U6-84 to U6-87	Online Subnet	Subnet currently available; U6-84 is the most significant octet	0 to 255
U6-88 to U6-91	Online Gateway	Gateway currently available; U6-88 is the most significant octet	0 to 255
U6-92	Online Speed	Link Speed	10: 10 Mbps 100: 100 Mbps
U6-93	Online Duplex	Duplex Setting	0: Half, 1: Full
U6-98	First Fault	First Option Fault	–
U6-99	Current Fault	Current Option Fault	–

7 Configuring Messaging

This section provides information on methods used to control the drive with the option installed.

◆ Drive Polled Configuration

The assemblies in [Table 8](#) are available for polled I/O:

Table 8 Supported Polled I/O Assemblies

Assembly Number (Hex)	Description	Type	Bytes	Page
20(14)	Basic Speed Control Output	Output	4	26
21(15)	Extended Speed Control Output	Output	4	27
22(16)	Speed and Torque Control Output	Output	6	–
23(17)	Extended Speed and Torque Control Output	Output	6	–
70(46)	Basic Speed Control Input	Input	4	28
71(47)	Extended Speed Control Input	Input	4	29
72(48)	Speed and Torque Control Input	Input	6	–
73(49)	Extended Speed and Torque Control Input	Input	6	–
100(64)	(Vendor Specific Yaskawa Electric (YE) Assy)-MEMOBUS/Modbus Message Output	Output	5	–
101(65)	(Vendor Specific Yaskawa Electric (YE) Assy)-Speed/Torque Control Output	Output	8	–
116(74)	(Vendor Specific Yaskawa Electric (YE) Assy)-High Speed/Torque Control Output	Output	44	–
150(96)	(Vendor Specific Yaskawa Electric (YE) Assy)-MEMOBUS/Modbus Message Input	Input	5	–
151(97)	(Vendor Specific Yaskawa Electric (YE) Assy)-Speed/Torque Status Input	Input	8	–
166(A6)	(Vendor Specific Yaskawa Electric (YE) Assy)-High Speed/Torque Status Input	Input	44	–

8 Output Assemblies (Drive Consumes)

8 Output Assemblies (Drive Consumes)

Note: The convention in this manual is from the PLC perspective. As such, an assembly is called an “Output Assembly” when outputted from the PLC and received by this node. This section details “Output Assemblies” that are “Consumed” by this drive.

◆ Basic Speed Control Output - 20 (0x14)

Output Instance	Byte	Bit 7	Bit 6	Bit 5	Bit 4	Bit 3	Bit 2	Bit 1	Bit 0
20	0	–	–	–	–	–	Fault Reset	–	Run Fwd
	1	–							
	2	Speed Reference (Low Byte)							
	3	Speed Reference (High Byte)							

Name	Description
Run Fwd	Forward Run Command 0: Stop 1: Forward Run
Fault Reset	Fault Reset (0 to 1 transition: Fault Reset)
Speed Reference	Speed Command Sets drive speed reference. Speed reference data: Frequency reference/2 ^{SS} (SS: Speed scale) Setting range: 0 to 0xFFFF Example: setting a reference of 4096 with a speed scale of 2: Speed reference data = $4096/2^2 = 1024 = 0x0400$ Hex or 10.24 Hz Unit depends on o1-03.

◆ Extended Speed Control Output - 21 (0x15)

Output Instance	Byte	Bit 7	Bit 6	Bit 5	Bit 4	Bit 3	Bit 2	Bit 1	Bit 0
21	0	–	NetRef	NetCtrl	–	–	Fault Reset	Run Rev	Run Fwd
	1	–							
	2	Speed Reference (Low Byte)							
	3	Speed Reference (High Byte)							

Name	Description
Run Fwd	Forward Run Command 0: Stop 1: Forward Run
Run Rev	Reverse Run Command 0: Stop 1: Reverse Run
Fault Reset	Fault Reset (0 to 1 transition: Fault Reset)
NetCtrl	Run command from Network 0: Depends on b1-02 1: Enables the run command from network
NetRef	Speed reference from Network 0: Depends on b1-01 1: Enables the speed reference from network
Speed Reference	Speed Command Sets drive speed reference. Speed reference data: Frequency reference/2 ^{SS} (SS: Speed scale) Setting range: 0 to 0xFFFF For example, when setting a reference of 4096 with a speed scale of 2: Speed reference data = 4096/2 ² = 1024 = 0x0400 Unit depends on o1-03.

9 Input Assemblies (Drive Produces)

Note: The convention in this manual is from the PLC perspective. An “Input Assembly” is outputted from this node and read by the PLC. This section details “Input Assemblies” that are “Produced” by this drive.

◆ Basic Speed Control Input - 70 (0x46)

Input Instance	Byte	Bit 7	Bit 6	Bit 5	Bit 4	Bit 3	Bit 2	Bit 1	Bit 0
70	0	–	–	–	–	–	Running 1 (FWD)	–	Faulted
	1	–							
	2	Speed Actual (Low Byte)							
	3	Speed Actual (High Byte)							

Parameter	Data
Faulted	Faulted 0: No Faults Occurred 1: Fault Occurred
Running 1 (FWD)	Forward Running 0: Stop or Reverse Running 1: Forward Running
Speed Actual	Actual Drive Speed Monitors drive output frequency. Speed actual data: Output frequency x 2 ^{SS} (SS: Speed scale) Range: 0 to 0xFFFF For example, when output frequency of 1024 with a speed scale of 2: Speed actual data = 1024 x 2 ² = 4096 = 0x1000 Unit depends on o1-03.

9 Input Assemblies (Drive Produces)

◆ Extended Speed Control Input - 71 (0x47)

Input Instance	Byte	Bit 7	Bit 6	Bit 5	Bit 4	Bit 3	Bit 2	Bit 1	Bit 0
71	0	At Speed	Ref from Net	Ctrl from Net	Ready	Running 2 (REV)	Running 1 (FWD)	Warning	Faulted
	1	Drive State							
	2	Speed Actual (Low Byte)							
	3	Speed Actual (High Byte)							

Name	Description
Faulted	Faulted 0: No Faults Occurred 1: Fault Occurred
Warning	Warning 0: No Warning Occurred 1: Warning Occurred
Running 1 (FWD)	Forward Running 0: Stop or Reverse Running 1: Forward Running
Running 2 (REV)	Reverse Running 0: Stop or Forward Running 1: Reverse Running
Ready	Drive Ready 0: Not Ready 1: Ready
Ctrl from Net	Status of Run command from Network 0: Run command is not from network 1: Run command is from network
Ref from Net	Status of Speed reference from Network 0: Speed reference is not from network 1: Speed reference is from network
At Speed	Speed Agree 0: No Speed Agree 1: Speed actual at speed reference
Drive State	Contains the value from the Control Supervisor (Class 0x29) Instance 1 Attribute 6.
Speed Actual	Actual Drive Speed Monitors drive output frequency. Speed actual data: Output frequency $\times 2^{SS}$ (SS: Speed scale) Range: 0 to 0xFFFF For example, when output frequency of 1024 with a speed scale of 2: Speed actual data = $1024 \times 2^2 = 4096 = 0x1000$ Unit depends on o1-03.

10 Web Interface

The web server interface to the option allows management of diagnostic information through a standard web browser. The embedded web pages include:

- Main page (Information)
- Drive Status page (Status, Monitor and Fault History)
- Network Monitor page (Network Monitor)

◆ Main Page (information)

The embedded main page shows basic option information such as vendor ID, serial number, MAC address, and firmware version. This page also shows the status of the option and provides links to the other embedded web pages.

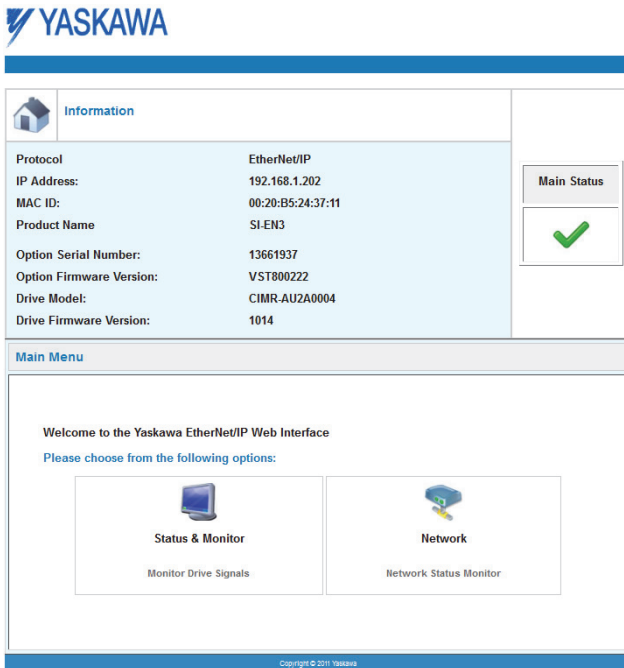

Figure 10 Main Page View

◆ Drive Status Page (Status, Monitor and Fault History)

The embedded drive status page shows basic I/O information and drive state information.

YASKAWA

Status, Monitor and Fault History

Drive Signals

Stopped	On	Forward	On	Alarm	Off
Running	Off	Reverse	Off	Fault	Off

Drive Signals			Multi-function Inputs		Multi-function Outputs	
Frequency Ref.	0.00 Hz		Terminal S1	Off	Output M1-M2	Off
Output Frequency	0.00 Hz		Terminal S2	Off	Output M3-M4	On
Output Current	0.0	A	Terminal S3	Off	Output M5-M6	Off
DC Bus Voltage	344	VDC	Terminal S4	Off		
Torque Ref	0.0	%	Terminal S5	Off		
			Terminal S6	Off		
			Terminal S7	Off		
			Terminal S8	Off		
			Terminal S9	NA		
			Terminal S10	NA		
			Terminal S11	NA		
			Terminal S12	NA		

Analog Input Signals

Input Terminal A1	0.0	%
Input Terminal A2	0.0	%
Input Terminal A3	0.0	%

Fault Information

Active: None

Copyright © 2011 Yaskawa

Figure 11 Drive Status Page View

10 Web Interface

◆ Network Monitor Page (Network Monitor)

The embedded network monitor page shows the status of the option network traffic and open I/O connections.

The screenshot shows the YASKAWA Network Monitor web interface. At the top is the YASKAWA logo. Below it is a navigation bar with a home icon and the text 'Network Monitor'. The main content area is divided into three sections: 'Diagnostics', 'Connection 1', and 'Connection 2'. Each section contains a table of network statistics. Below each connection's table is a 'Reset Statistics' button.

Diagnostics					
Msg. TX OK	6714	Msg. TX Dropped	0	Msg. TX Errors	0
Msg. Rx OK	10377	Msg. Rx Dropped	0	Msg. RX Errors	0
Current Connections	0	Collisions	0	TX Retry	0

Connection 1					
Originator IP Address	0.0.0.0			Time out Multiplier	0
O2T_RPI	0	O2T_API	0	Consume Msg Cnt	0
T2O_RPI	0	T2O_API	0	Produce Msg Cnt	0

Connection 2					
Originator IP Address	0.0.0.0			Time out Multiplier	0
O2T_RPI	0	O2T_API	0	Consume Msg Cnt	0
T2O_RPI	0	T2O_API	0	Produce Msg Cnt	0

Copyright © 2011 Yaskawa

Figure 12 Network Monitor Page View

Table 9 Network Monitor Explanations

Network Monitor	Explanation
Msg Tx OK	Cumulative number of messages transmit successfully from the option.
Msg Rx OK	Cumulative number of messages received successfully to the option.
Current Connections	Current number of open connections.
Msg Tx Dropped	Cumulative number of messages dropped due to output network buffer being full and unable to hold the new message.
Msg Rx Dropped	Cumulative number of messages dropped due to input network buffer being full and unable to hold the new message.
Collisions	Cumulative number of collisions.
Msg Tx Errors	Cumulative number of transmit errors.
Msg Rx Errors	Cumulative number of receive errors.
Tx Retry	Cumulative number of transmit errors.
Originator IP Address	The IP address of the network node making this connection.
Time out Multiplier	The value here specifies the multiplier applied to the expected packet rate (API) to obtain the value used by the inactivity timer for this connection.
O2T_RPI	Originator to Target (ie, PLC to SI-EN3) Requested Packet Interval for I/O messaging, in milliseconds, for this connection.
O2T_API	Originator to Target (ie, PLC to SI-EN3) Actual Packet Interval for I/O messaging, in milliseconds, for this connection.
Consume Msg Cnt	Number of I/O messages consumed (ie, received) from the SI-EN3 since the connection was established or statistics were reset for this connection.
T20_RPI	Target to Originator (ie, SI-EN3 to PLC) Requested Packet Interval for I/O messaging, in milliseconds, for this connection.
T20_API	Target to Originator (ie, SI-EN3 to PLC) Actual Packet Interval for I/O messages, in milliseconds, for this connection.
Produce Msg Cnt	Number of IO messages produced (ie, transmit) from the SI-EN3 since the connection was established or statistics were reset for this connection.
Reset Statistics Connection1	Clicking this resets the Consume Msg Cnt and the Produce Msg Cnt for this connection to start counting from zero.

Note: Network monitors are reset when the power supply is cycled.

11 Troubleshooting

◆ Drive-Side Error Codes

Drive-side error codes appear on the drive digital operator. Causes of the errors and corrective actions are listed in *Table 10*. For additional error codes that may appear on the drive digital operator, refer to the drive Technical Manual.

■ Faults

Both bUS (option communication error) and EF0 (External fault input from the option) can appear as an alarm or as a fault. When a fault occurs, the digital operator ALM LED remains lit. When an alarm occurs, the ALM LED flashes.

If communication stops while the drive is running, use the following questions as a guide to help remedy the fault:

- Is the option properly installed?
- Is the communication line properly connected to the option? Is it loose?
- Is the controller program working? Has the controller/PLC CPU stopped?
- Did a momentary power loss interrupt communications?

Table 10 Fault Display and Possible Solutions

LED Operator Display		Fault Name
bUS	bUS	Option Communication Error
		<ul style="list-style-type: none"> • After establishing initial communication, the connection was lost • Only detected when the run command or frequency reference is assigned to the option (b1-01 = 3 or b1-02 = 3)
Cause		Possible Solution
Master controller (PLC) has stopped communicating		<ul style="list-style-type: none"> • Check that power is supplied to the PLC • Check that PLC is not in program mode
Communication cable is not connected properly		<ul style="list-style-type: none"> • Check for faulty wiring • Correct any wiring problems
A data error occurred due to noise		<ul style="list-style-type: none"> • Inspect items that can minimize the effects of electrical noise • Counteract noise in the control circuit, main circuit, and ground wiring • If a magnetic contactor is identified as a source of noise, install a surge absorber to the contactor coil • Make sure the cable used meets the EtherNet/IP requirements • Make sure the option ground wire is connected between option FE terminal and the drive ground terminal connected to earth ground
Option is damaged		If there are no problems with the wiring and the error continues to occur, replace the option.
Connection Time-out		<ul style="list-style-type: none"> • The option Requested Packet Interval (RPI) timer timed out • Make sure that RPI time is set properly

Duplicate IP Address	Check if the option shares IP Address with at least one other node. Check the setting values of F7-01 to F7-04.
----------------------	--

LED Operator Display		Fault Name
EFO	EFO	Option Card External Fault
		The alarm function for an external device has been triggered.
Cause		Corrective Action
An external fault is being sent from the upper controller (PLC)		<ul style="list-style-type: none"> Remove the cause of the external fault Reset the external fault input from the PLC device
Problem with the PLC program		Check the program used by the PLC and make the appropriate corrections.
PLC is in the Idle Mode.		<ul style="list-style-type: none"> Set the PLC to the Run Mode. Set the drive parameter F6-54 to 0 (Enabled) not to detect errors while the PLC is in the Idle Mode.

LED Operator Display		Fault Name
oFA00	oFA00	Option Card Connection Error (CN5-A)
		Option is not properly connected.
Cause		Possible Solution
Non-compatible option connected to the drive		Connect an option that is compatible with the drive.

LED Operator Display		Fault Name
oFA01	oFA01	Option Card Fault (CN5-A)
		Option is not properly connected.
Cause		Possible Solution
Problem with the connectors between the drive and option		Turn the power off and check the connectors between the drive and option.

LED Operator Display		Fault Name
oFA03	oFA03	Option Card Error (CN5-A)
		Option self-diagnostics error.
Cause		Possible Solution
Option hardware fault		Replace the option.

11 Troubleshooting

LED Operator Display		Fault Name
	oFA04	Option Card Error (CN5-A)
		Option flash write mode.
Cause		Possible Solution
Option hardware fault		Replace the option.

LED Operator Display		Fault Name
	oFA30 to oFA43	Option Card Connection Error (CN5-A)
		Communication ID error.
Cause		Possible Solution
Option hardware fault		Replace the option.

LED Operator Display		Fault Name
	oFb00	Option Fault (CN5-B)
		Non-compatible option is connected.
Cause		Possible Solution
Non-compatible option connected to the drive.		Connect the correct option to CN5-A.

LED Operator Display		Fault Name
	oFb02	Option Fault (CN5-B)
		Two identical options are connected at the same time.
Cause		Possible Solution
Options AI-A3 or DI-A3 are connected to the CN5-B port with an option connected to CN5-A.		<ul style="list-style-type: none"> • Only one type of AI-A3 or DI-A3 option can be connected to the drive • The SI-EN3 option can only be connected to CN5-A

LED Operator Display		Fault Name
	oFc00	Option Fault (CN5-C)
		Non-compatible option is connected.
Cause		Possible Solution
Non-compatible option connected to the drive.		Connect the correct option to CN5-A.

LED Operator Display		Fault Name
oFc02	oFc02	Option Fault
		Option Flash write mode.
Cause		Possible Solution
Options AI-A3 or DI-A3 are connected to the CN5-B port while an option connected to CN5-A.		<ul style="list-style-type: none"> Only one type of AI-A3 or DI-A3 option can be connected to the drive The SI-EN3 option can only be connected to CN5-A

■ Minor Faults and Alarms

LED Operator Display		Minor Fault Name	
CALL	CALL	Serial communication transmission error	
		Communication is not established.	
Cause		Possible Solution	Minor Fault (H2-□□ = 10)
Communication wiring is faulty, there is a short circuit, or improper connection.		Check for wiring errors: <ul style="list-style-type: none"> Correct the wiring Remove ground shorts and reconnect loose wires 	YES
Programming error on the master side.		Check communications at start-up and correct programming errors.	
Communication circuitry is damaged.		<ul style="list-style-type: none"> Perform a self-diagnostics check Replace the drive if the fault continues to occur 	

■ Explicit Message Communications Errors

When there is a problem with a request message sent from the master in explicit communications, the drive will return one of the following error codes.

Error Code (hex)	Description	Cause	Possible Solution
08	Service not supported	The service code is incorrect.	Correct the service code.
09	Invalid attribute value	The attribute is incorrect.	Correct the attribute.
0C	Object state conflict	Attempted to change an drive constant that cannot be changed while the drive is running.	Stop the drive.
0E	Attribute not settable	Attempted to change a read-only attribute.	Correct the service code or attribute setting.
13	Not enough data	The data size is incorrect.	Correct the data size.

11 Troubleshooting

Error Code (hex)	Description	Cause	Possible Solution
14	Attribute not supported	Attempted to execute a service not defined for the attribute.	Correct the service code or attribute setting.
15	Too much data	The data size is incorrect.	Correct the data size.
16	Object does not exist	An unsupported object was specified.	Correct the class or instance setting.
1F	Vendor-specific error	Attempted to change a drive constant that cannot be changed while the drive is running. Attempted to change a drive constant to a value outside the setting range.	Stop the drive. Specify a value within the setting range.
20	Invalid parameter	Attempted to change to a data value outside the setting range.	Specify a data value within the setting range.

Note: Refer to the MEMOBUS/Modbus Data Table in the Technical Manual for a list of monitor data using the MEMOBUS/Modbus message area.

◆ Option Error Codes

■ Option Fault Monitors U6-98 and U6-99

The option can declare error/warning conditions via drive monitor parameters on the drive digital operator as shown in [Table 11](#).

Table 11 Option Fault Monitor Descriptions

Fault Condition	Fault Declared	Status Value (U6-98/U6-99)	Description
No Fault	n/a	0	No faults.
Force Fault	EF0	3	Network sent a message to force this node to the fault state.
Network Link Down	BUS ERROR	1100	No network link to option.
Connection Time-out	BUS ERROR	1101	The node timer (Requested Packet Interval) timed out.
Duplicate IP Address	BUS ERROR	1102	This node and at least one other node have the same IP Address.
Default MAC Address	None	1103	Factory default MAC Address programmed into the option. Return for reprogramming.

Two drive monitor parameters, U6-98 and U6-99 assist the user in network troubleshooting.

- U6-98 displays the first declared fault since the last power cycle. U6-98 is only cleared upon drive power-up.

- U6-99 displays the present option status. U6-99 is cleared upon a network-issued fault reset and upon power-up.

If another fault occurs while the original fault is still active, parameter U6-98 retains the original fault value and U6-99 stores the new fault status value.

◆ Option Compatibility

A limited number of options may be simultaneously connected to the drive depending on the type of option. Refer to [Table 12](#) for more information. More details can be found in the Options and Peripheral Devices chapter of the drive Technical Manual.

Table 12 Option Installation Compatibility

Option	Connector	Number of Possible Options
SI-C3, SI-N3, SI-P3, SI-S3, SI-EN3 etc. <1>	CN5-A	1
PG-B3, PG-X3 etc.	CN5-B, C	2 <2>
DO-A3, AO-A3, AI-A3, DI-A3 etc.	CN5-A, B, C	1

<1> When installed in CN5-A, the AI-A3 and DI-A3 options can be used to set the frequency reference or replace the drive analog inputs with higher resolution. When installed in CN5-B or CN5-C, these options can only be used for monitoring; their input levels will be displayed in U1-17 or U1-21 to U1-23.

<2> Use the CN5-C connector when connecting only one option to the drive; use both CN5-B and CN5-C when connecting two options.

12 Specifications

◆ Specifications

Table 13 Option Specifications

Item	Specification
Model	SI-EN3
Supported Messages	<ul style="list-style-type: none"> • Explicit: Explicit Class 3, Unconnected • I/O: Class 1, Listen Only, Input Only
I/O Assembly Instance	<ul style="list-style-type: none"> • Input: 7 types (4 to 44 Bytes) • Output: 7 types (4 to 44 Bytes)
SI-EN3 Specification	Conformance Level A6: Passed
SI-EN3 Profile	AC Drive
Connector Type	RJ45 8-pin Straight Connector STP Cat 5e cable
Physical Layer Type	<ul style="list-style-type: none"> • Isolated Physical Layer • TCP Protocol Transformer Isolated
IP Address Setting	Programmable from drive keypad or network
Communication Speed	Programmable from drive keypad or network: 10/100 Mbps, auto-negotiate
Number of Connections	<ul style="list-style-type: none"> • I/O: 2 • Explicit: 6
Duplex Mode	Half-forced, Auto-negotiate, Full-forced
Address Startup Mode	Static, BOOTP, DHCP
Ambient Temperature	-10°C to +50°C (14°F to 122°F)
Humidity	95% RH or lower with no condensation
Storage Temperature	-20°C to +60°C (-4°F to 140°F) allowed for short-term transport of the product
Area of Use	Indoor (free of corrosive gas, airborne particles, etc.)
Altitude	1000 m (3280 ft.) or lower

◆ Revision History

The revision dates and the numbers of the revised manuals appear on the bottom of the back cover.

MANUAL NO. TOBP C730600 58A

Published in Japan March 2012 12-03

└─ Date of original publication
└─ Date of publication

Date of Publication	Revision Number	Section	Revised Content
March 2012	–	–	First edition

YASKAWA AC Drive 1000-Series Option

EtherNet/IP

Installation Manual

YASKAWA ELECTRIC CORPORATION

New Pier Takeshiba South Tower, 1-16-1, Kaigan, Minatoku, Tokyo, 105-6891, Japan

Phone: 81-3-5402-4502 Fax: 81-3-5402-4580

<http://www.yaskawa.co.jp>

YASKAWA AMERICA, INC.

2121 Norman Drive South, Waukegan, IL 60085, U.S.A.

Phone: (800) YASKAWA (927-5292) or 1-847-887-7000 Fax: 1-847-887-7310

<http://www.yaskawa.com>

YASKAWA EUROPE GmbH

Hauptstrasse 185, 65760 Eschborn, Germany

Phone: 49-6196-569-300 Fax: 49-6196-569-398

<http://www.yaskawa.eu.com>



YASKAWA ELECTRIC CORPORATION

In the event that the end user of this product is to be the military and said product is to be employed in any weapons systems or the manufacture thereof, the export will fall under the relevant regulations as stipulated in the Foreign Exchange and Foreign Trade Regulations. Therefore, be sure to follow all procedures and submit all relevant documentation according to any and all rules, regulations and laws that may apply.

Specifications are subject to change without notice for ongoing product modifications and improvements.

© 2012 YASKAWA ELECTRIC CORPORATION. All rights reserved.

MANUAL NO. TOEP C730600 58A

Published in Japan March 2012 12-3

11-12-7